

“Building Energy Analysis” Course Notes – Fall 2021
Prepared by D. Mather

HV1: ASPECTS OF HVAC SYSTEMS

1. Roles of HVAC Systems
2. Single-Zone, Air-Based Heating and Cooling Systems
3. Useful References
4. HVAC Fans
5. Fan Laws for Shaft-Speed Changes
6. Electric Motors for HVAC Fans and Pumps
7. Motor Speed and Shaft-Power at Part-Load
8. Motor Efficiency at Part-Load
9. Fan & Motor Installed in a Duct-System
10. Simple Hydronic Heating System
11. Space Heating Boilers
12. Seasonal Boiler Efficiency

Problems

Solutions

Module Overview

This module discusses aspects of HVAC systems, with a focus on some basic calculations for centrifugal fans and AC induction motors.

Relevant Course Intended Learning Outcomes:

- Apply basic energy calculations to a variety of components and systems impacting building energy use.
- Recognize the interactive effects between different building components and systems as related to energy use.
- Apply simple analysis techniques in building energy auditing and simulation,

1. Roles of HVAC Systems

Some key needs addressed by HVAC systems:

1. Maintain Thermal Comfort Conditions

Compensate for net energy losses/gains to maintain thermal comfort. Generally accomplished by heating, cooling, humidifying, dehumidifying, and inducing air-movement.

2. Maintain Acceptable Indoor Air Quality

Compensate for “air pollutant generation” to maintain acceptable indoor air quality (IAQ). Generally accomplished by filtration, ventilation, and exhaust.

HVAC designers generally refer to standards/guidelines to determine good-practice/design-criteria for thermal comfort and indoor air quality. For example:

ASHRAE Standard 62.1 “Ventilation for Acceptable Indoor Air Quality”

- Defines outdoor air ventilation rates expected to provide IAQ that will be acceptable to most people under normal circumstances.
- For example: HVAC systems for office spaces will typically be designed to deliver about 8 to 10 L/s of outdoor per person.

Other needs met by HVAC may include health & safety considerations, e.g:

- Pollutant extraction (e.g. fume hoods, welding hoods, kitchen smoke/fumes).
- Fire safety/suppression (e.g. smoke control during fire event).

Basic Components of HVAC Systems and Equipment

Many of the components of HVAC systems fit into one of the following categories. The wide variety of systems and devices are often simply different combinations and arrangements of the items listed.

- Motors, fans, pumps
- Ducts, pipes, fittings
- Heat-exchangers (e.g. air coils)
- Burners (e.g. in a furnace, boiler)
- Compressors (e.g. in an air-conditioner, heat pump, chiller)
- Controls (e.g. thermostats)
- Working fluids (e.g. air, water & additives, refrigerants)

Thermal Zones

In HVAC Engineering, a “thermal zone” (or “HVAC zone”) generally refers to a space in a building with HVAC equipment under the control of a particular thermostat.

For example, in a school where several classrooms each have a thermostat to control heating/cooling for that room, then each classroom would be considered a thermal zone. Or, where several rooms have their HVAC equipment controlled by a single thermostat then this collection of rooms may be considered a thermal zone. For example, a group of three offices where a thermostat in the middle office controls heating for all three, or a house where a single thermostat controls the heating and cooling (furnace and central air-conditioner) for the entire house (i.e. a collection of rooms).

In many buildings, several thermal zones may have shared HVAC equipment. For example, a boiler may deliver heat to several thermal zones via a hydronic distribution system, or an air-handling unit may deliver air to several thermal zones. However, it is very common that an HVAC system is dedicated to conditioning only a single thermal zone. For example, “the job” of a furnace in a house (with a single-thermostat) is to heat that single thermal zone (i.e. the house).

2. Single-Zone, Air-Based Heating and Cooling Systems (Part 1)

In many commercial buildings, HVAC units are used that serve just one thermal zone. It is very common that these systems use ducted-air as the means of distributing heating and cooling to that thermal zone. These are the systems considered in this section.

Single-zone HVAC systems can be relatively simple and may be viewed as sharing many similarities with the central furnaces and air-conditioners used in houses. To discuss the topic, we'll first look at some typical* household heating and cooling equipment. Then—by slight adjustment of the arrangement of the equipment—it will be converted to its approximate commercial equivalent: a “packaged rooftop unit” air-conditioner.

* “Typical” as used here refers to the general type of equipment used in many Canadian homes during the last 1-2 decades.

VIDEOS:

Watch the following two brief videos providing basic information on the operation of typical household central heating and air-conditioning systems. (Note: I-P units are used in the videos. Conversion factor: $1\text{ kW} \approx 3412\text{ btu/hr.}$)

1. [How Does a Furnace Work? — HVAC Repair & Troubleshooting Tips](#) (8 mins)

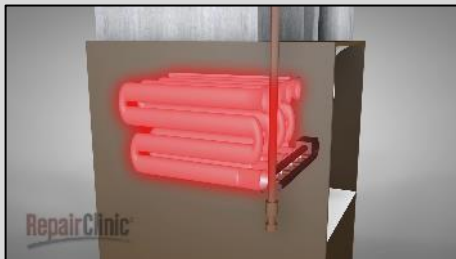

2. [How Does a Central Air Conditioner Work? — HVAC Repair Tips](#) (6 mins)

Notes about Video #2:

- The content from about 3:50 until the end is the same as some content in Video #1, so you might want to watch #2 only until 3:50.
- At 3:10, the narrator says “The compressor converts the gas back into a liquid...” but they really ought to say “The compressor *and condenser coil working together* converts the gas back into a liquid...”



Air Conditioner Condenser Unit



Evaporator Coil
(inside duct, as indicated)

Furnace

heat exchanger section

burner section

air filter

return air



ventor (or inducer)
(i.e. fan and motor)

indoor fan
and motor

Example Components in a Household Central Heating and Cooling System

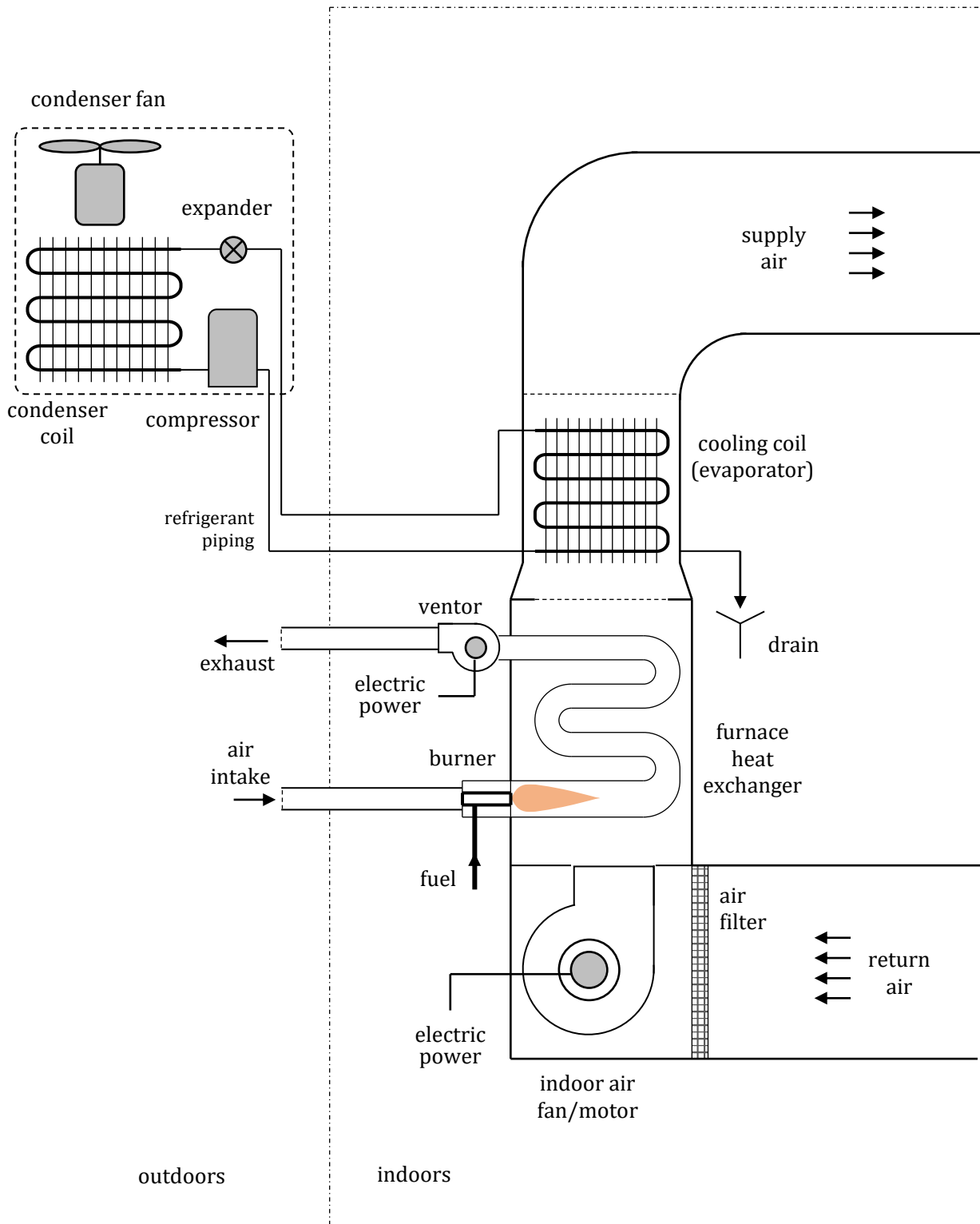

Schematic Representation

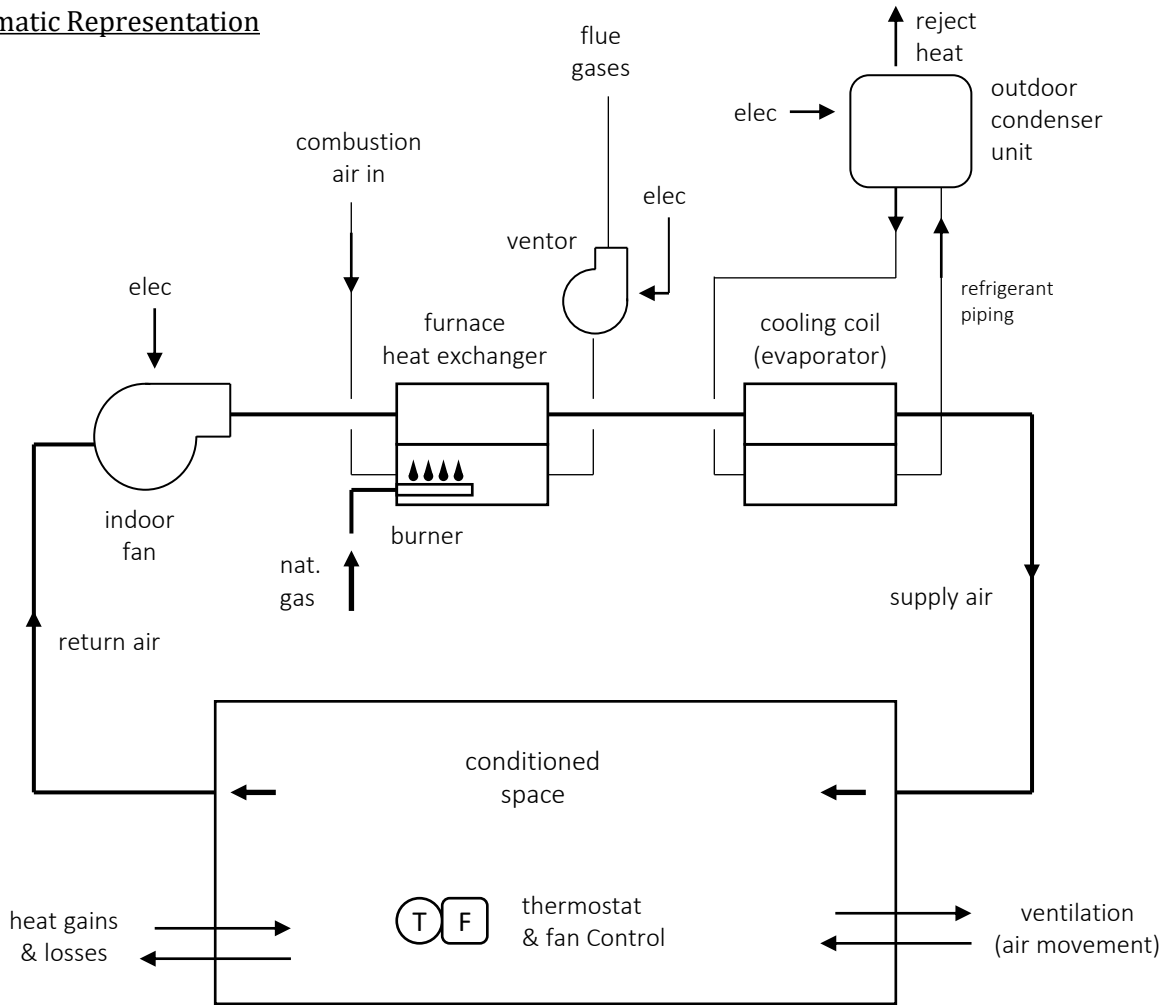

Highly Simplified Schematic Representation

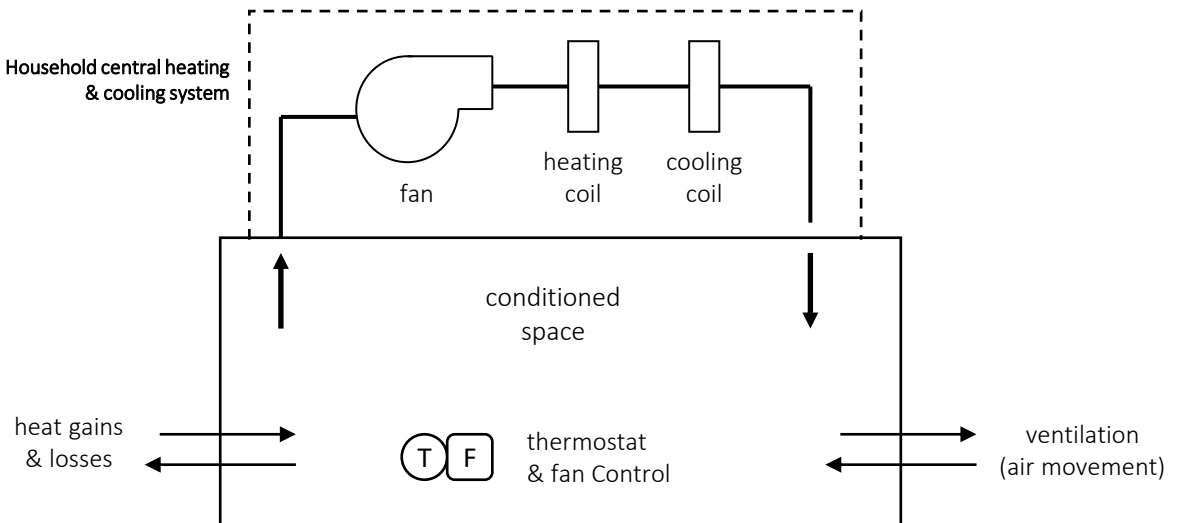

Simple Commercial Building HVAC Systems

In a house, the central furnace and air-conditioner *usually* provide only for thermal comfort (i.e. heating/cooling). IAQ requirements related to ventilation are achieved other means, e.g. air leakage and/or openings (windows).

In commercial buildings, “opening the window to let in some fresh air” is often not an option. Therefore, HVAC systems for buildings usually need to have provisions to deal with both thermal comfort and IAQ needs.

Now, slightly modifying the previous system to allow fresh air intake and building air exhaust:

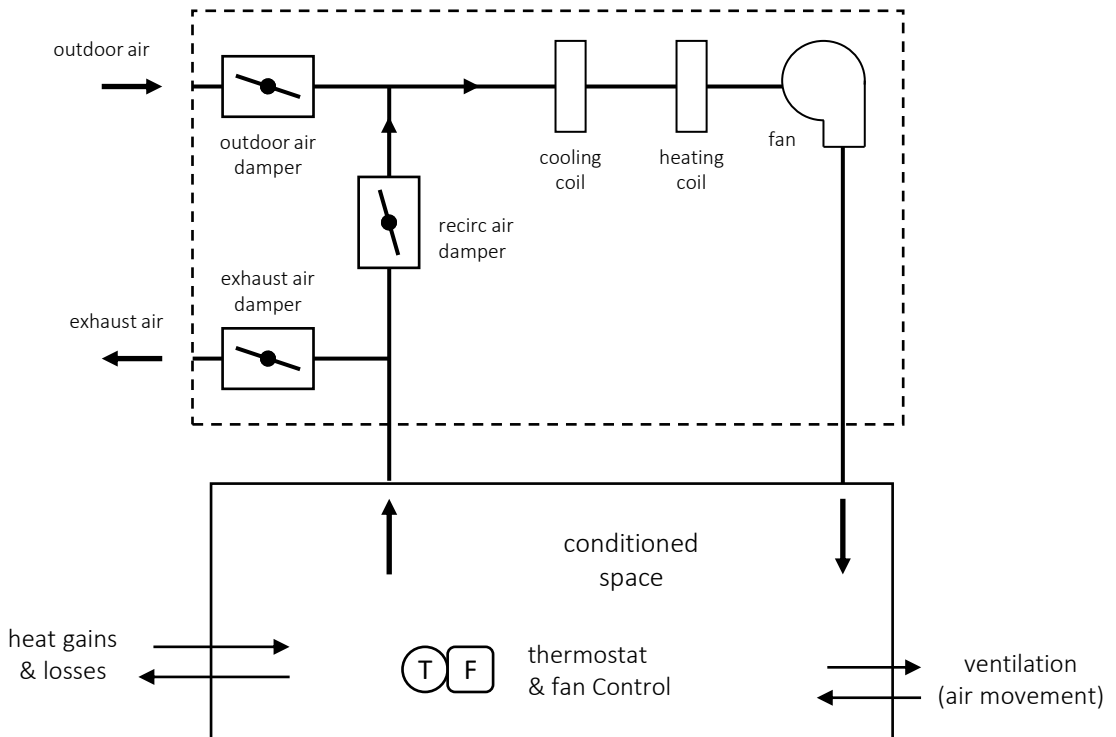

VIDEOS:

Please watch 2 more videos:

["How Air Handling Units Work"](#)
(13 mins)



["Rooftop Units Explained"](#)
(10 mins)

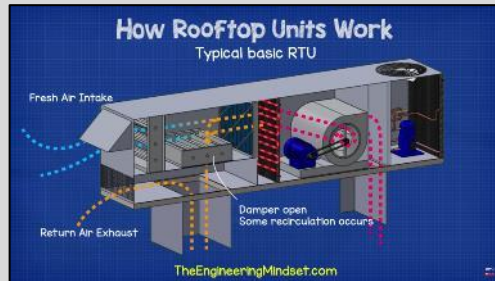

Key Components of Typical "Roof-Top Unit"

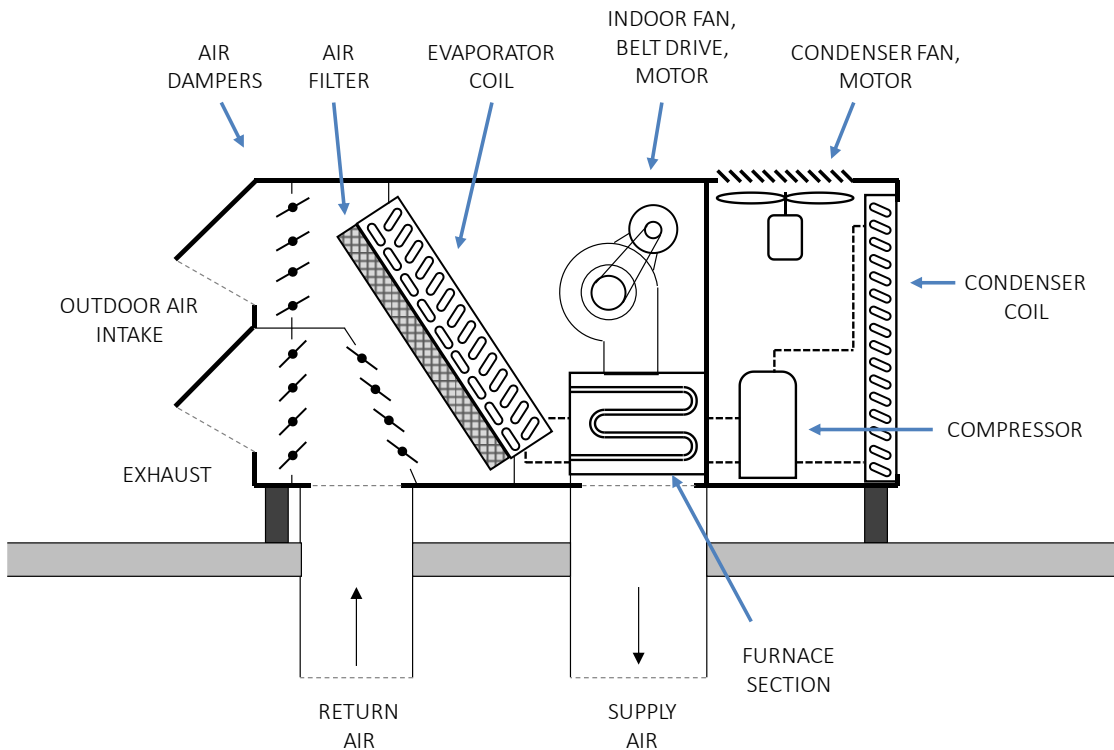

Air-Side Economizer

Dampers are automatically controlled to increase the OA% above the minimum when doing so will reduce energy use (e.g. call for cooling when outside air is cool). When outside conditions are quite cold or quite hot, the dampers will be set to min OA position.

Dampers at “Minimum Outdoor Air” Position

Dampers set to provide the minimum outdoor air amount needed to satisfy indoor air quality requirements (i.e. ASHRAE Standard 62.1).

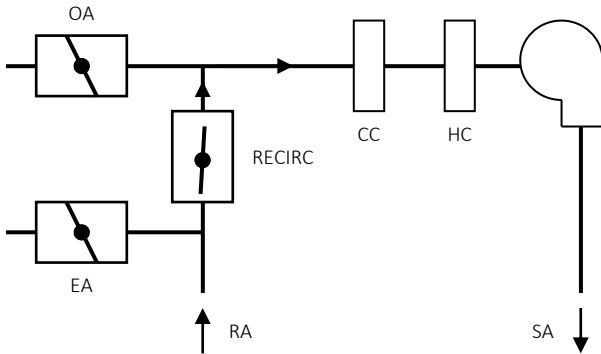
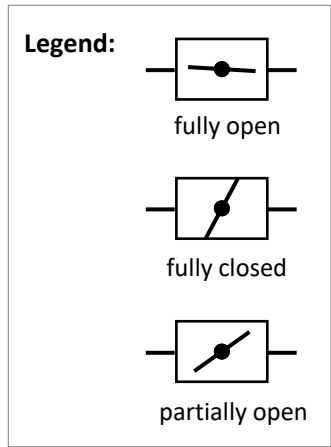

Supply Air = 0% outdoor air (100% recirc)

OA = fully closed
 EA = fully closed
 RECIRC = fully open

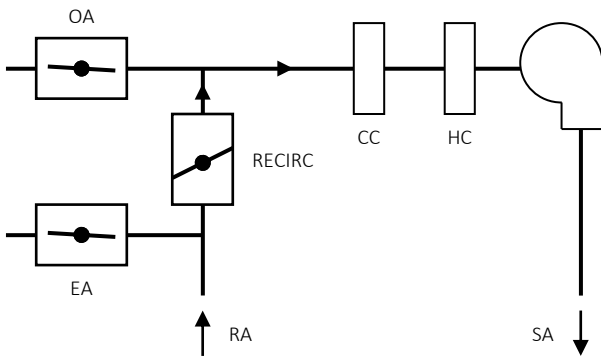

Supply Air = 100% outdoor air (0% recirc)

OA = fully open
 EA = fully open
 RECIRC = fully closed

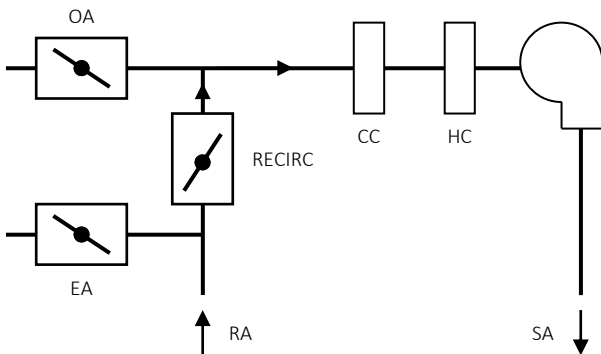

Supply Air = mixed air

OA = partially open
 EA = partially open
 RECIRC = partially open

} set as needed to achieve desired OA% in supply air

Single-Zone, Air-Based Heating and Cooling Systems (Part 2)

For those who looked at the use of a remote heater and fluid circulation through supply and return piping to provide the needed heating effect to a conditioned environment (i.e. a heated tank) in the EA2 module, a simplified schematic of this scenario is shown below. To maintain approximately constant temperature in the tank, the heater and circulation system must operate such that the time-averaged rate of heat added to the tank matches the heat loss rate.

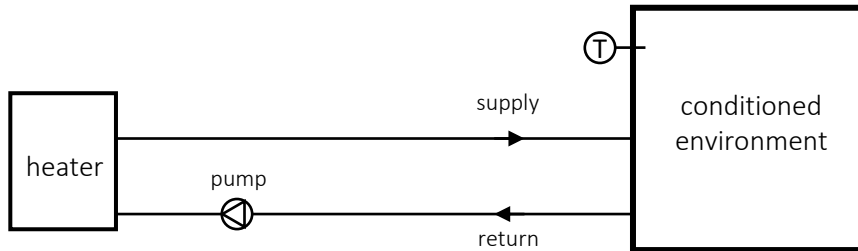

A simplified schematic of an air-based system providing heating and cooling only (i.e. no ventilation) is shown below. Only the "air-side" components are depicted (i.e. we do not see the equipment involved in causing the heating coil to become "hot", or the cooling coil to become "cold").

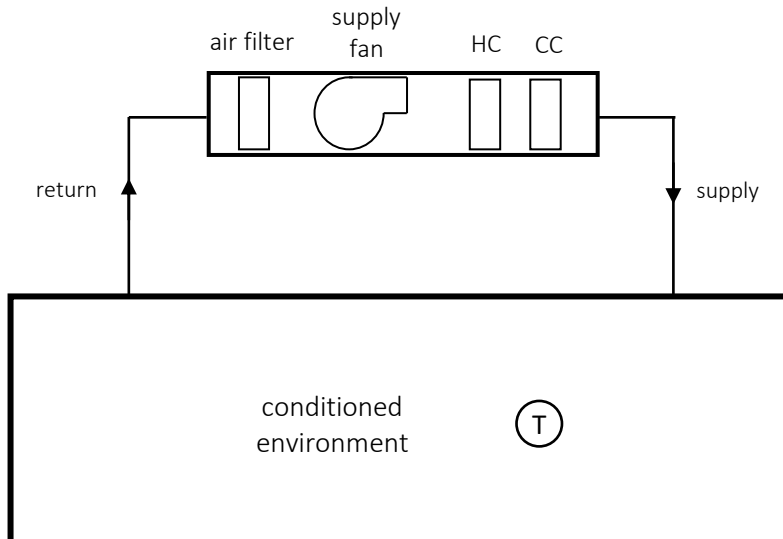

Hopefully we feel reasonably comfortable in making the small leap from the heated tank to the single zone air-based system. The conditioning unit changes the state (e.g. temperature) of the circulating fluid to try to keep the conditioned environment at reasonably steady temperature.

In the schematic below, an additional modification is made to the air-based system: ventilation and exhaust capability is added (with possibility to operate in air-side economizer mode). The unit is now a basic “rooftop unit”. This unit now has basic capabilities to provide heating and cooling to maintain reasonable thermal comfort, and ventilation to maintain reasonable indoor air quality.

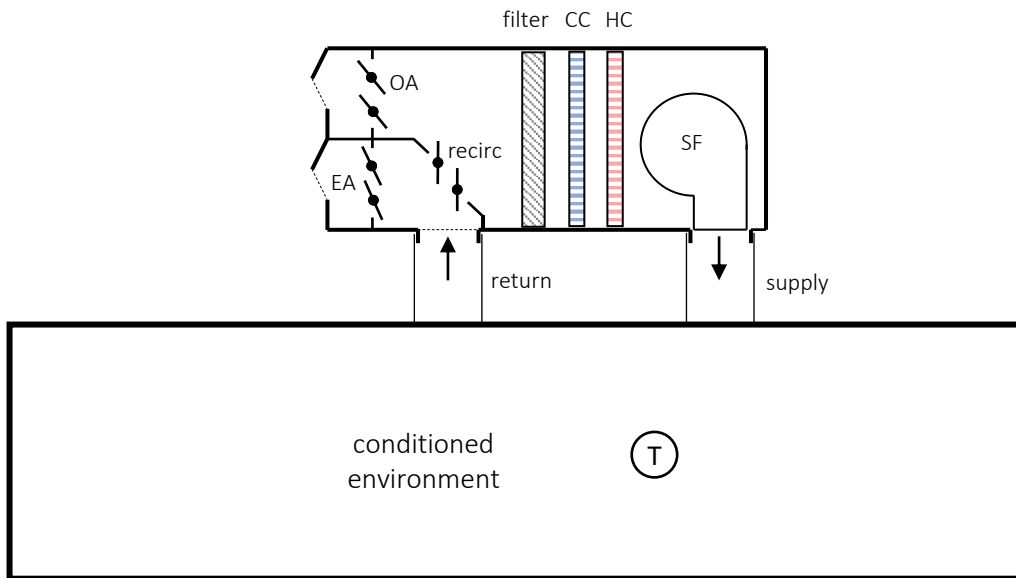

There is only one fan indicated in the above system. We should realize this fan now needs such capacity so it can accomplish its three “jobs”. It must be capable of delivering sufficient supply air during peak heating conditions and peak cooling conditions, and it must provide sufficient air for ventilation (indoor air quality)

In many HVAC systems, the supply fan runs at a constant speed when turned on. (We can think of this as an on/off fan control.) Given that the fan in the above system has three jobs (i.e. heating, cooling, ventilation—but not all three simultaneously), how should the “design circulation rate” (e.g. L/s of airflow) be determined?

Optional:

Example manufacturer’s technical info for packaged rooftop unit air-conditioners.

<https://docs.jci.com/ductedsystems/1068152-YTG-Z-0120>

(Note: It’s a very large and detailed document.)



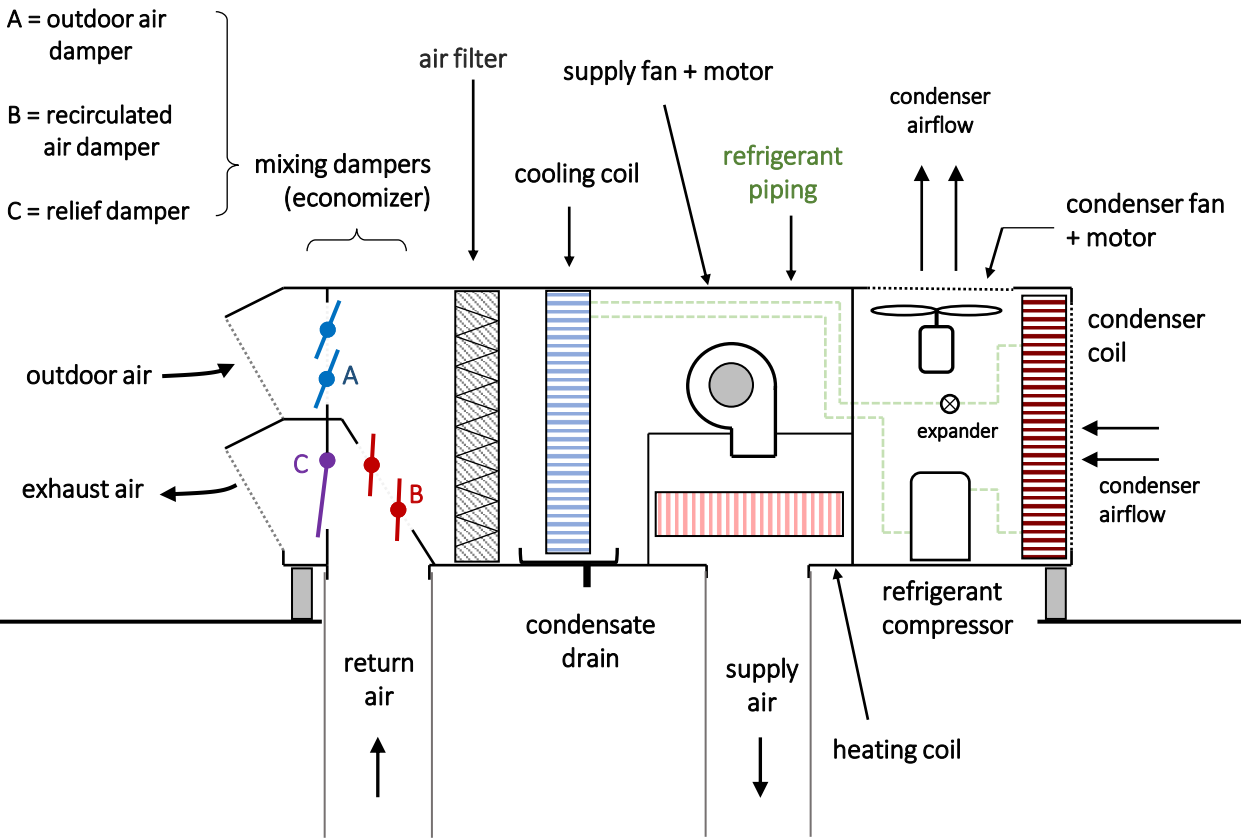

<https://www.esmagazine.com/articles/97730-rooftop-unit-carrier>

3. Useful References

It may be helpful at this point to revisit the PNNL [“Small Commercial Building Re-Tuning: A Primer”](#) document (i.e. from MP-1). It’s recommended that you skim through **Section 6.0** “Heating, Ventilation, and Air-Conditioning”.

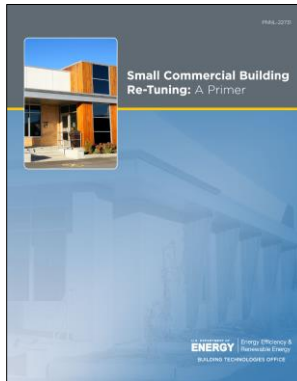

Other Useful References (optional)

For additional information on certain material covered in this module, the following references may be useful:

[“Improving Fan System Performance: A Sourcebook for Industry”](#) (see Section 1)
US DOE, 2003.

[“Continuous Energy Improvement in Motor Driven Systems: A Guidebook for Industry”](#) US DOE Office of Energy Efficiency and Renewable Energy, 2014.

[“Improving Motor and Drive System Performance: A Sourcebook for Industry”](#)
US DOE Office of Energy Efficiency and Renewable Energy, 2014.

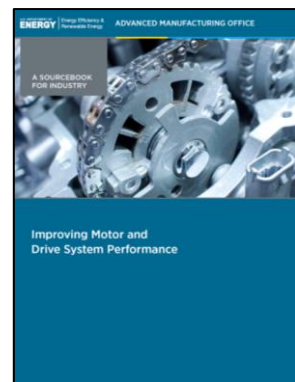
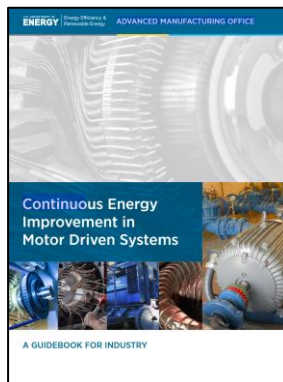
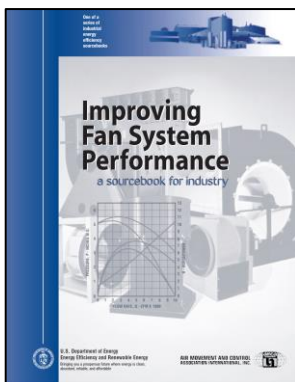

4. HVAC Fans

Recall the fan shaft power equation (from Module EA1):

$$\text{Fan shaft power: } \dot{W}_{sh} = \frac{\Delta P \cdot \dot{V}}{\eta_{fan}}$$

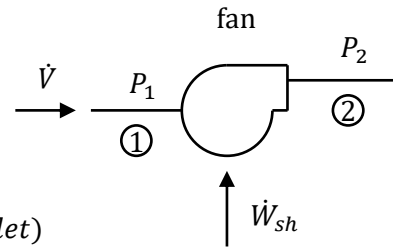

ΔP = pressure rise across fan (fan inlet to fan outlet)

\dot{V} = flow rate through fan

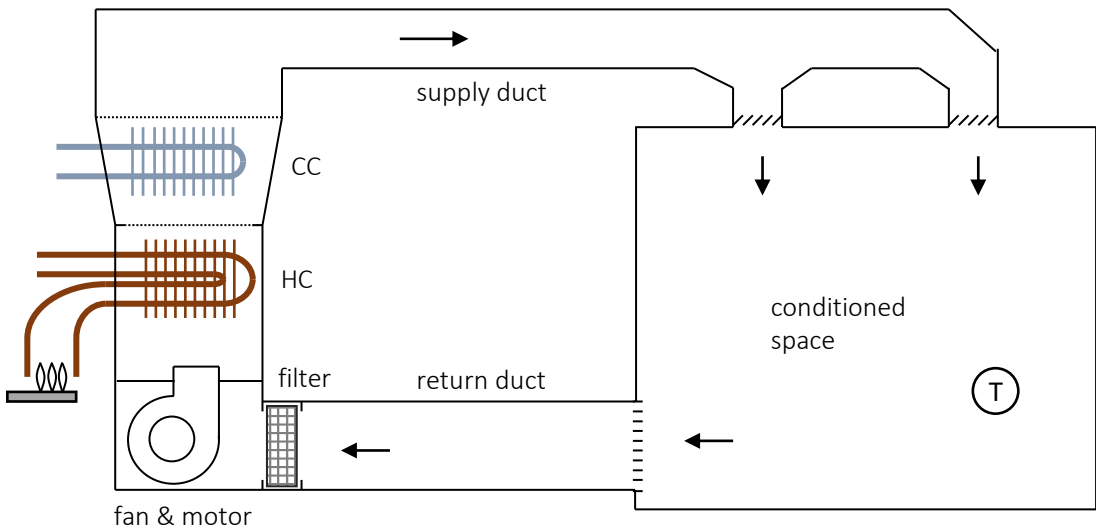

For a steadily operating “closed-loop” circulation system, the pressure rise across the fan is the overall pressure drop through the duct system, and the volumetric flow rate through the fan is the overall flow rate through the duct system.



TYPICAL CENTRIFUGAL FAN

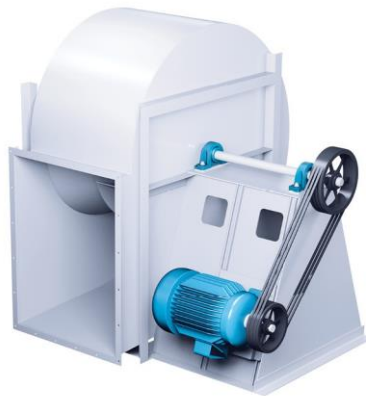
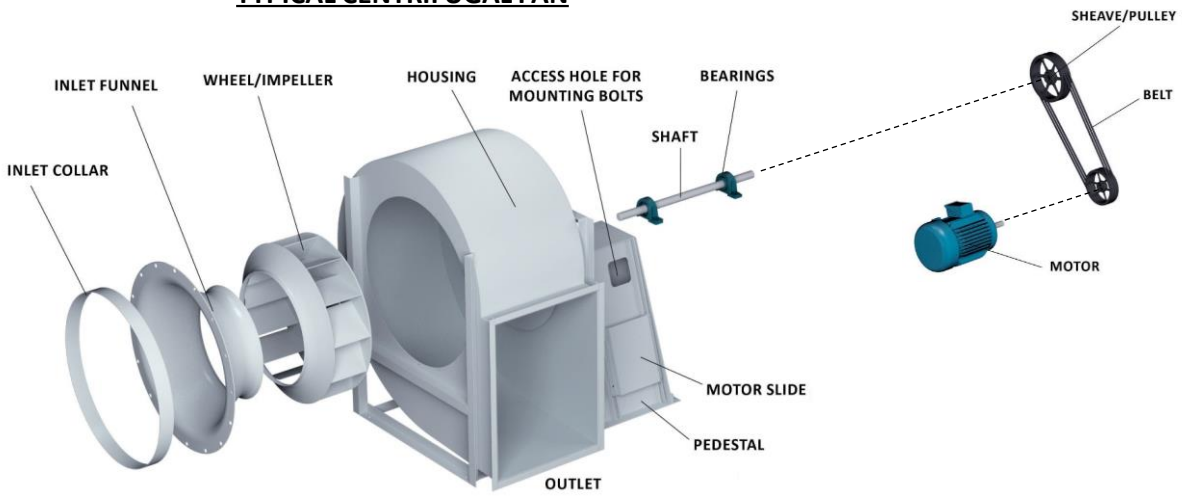

Diagrams adapted from Aerovent, <https://www.aerovent.com/products/centrifugal-fans/>

Typical “Backward-Curved” Fan Performance:

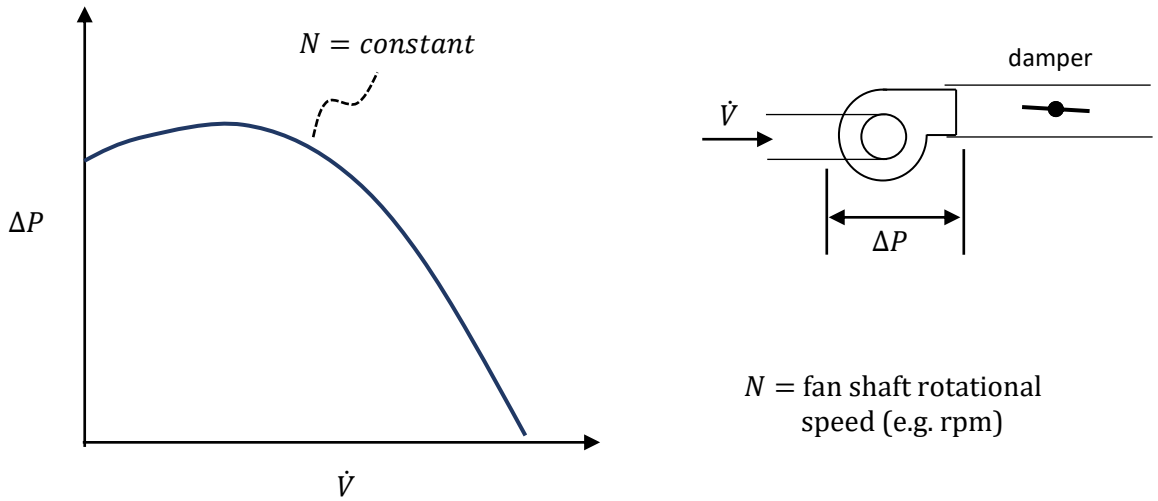

While the fan is driven at constant rotational speed, its “performance curve” can be measured. This indicates the combinations of \dot{V} and ΔP that may be obtained at that speed.

Impact of Fan Speed (i.e. fan shaft speed):

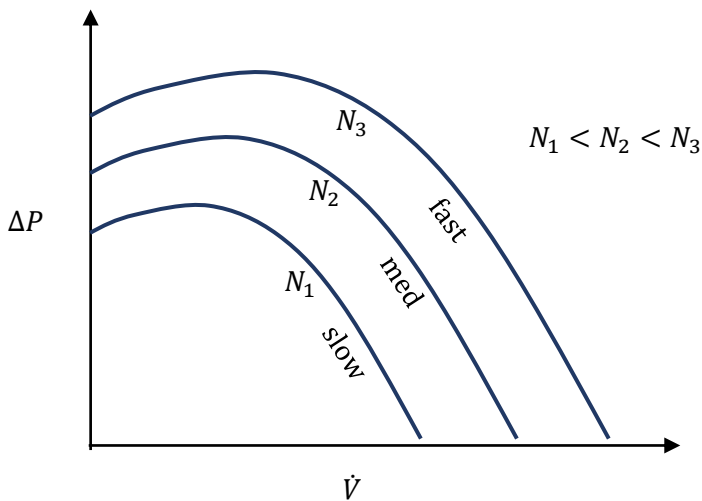

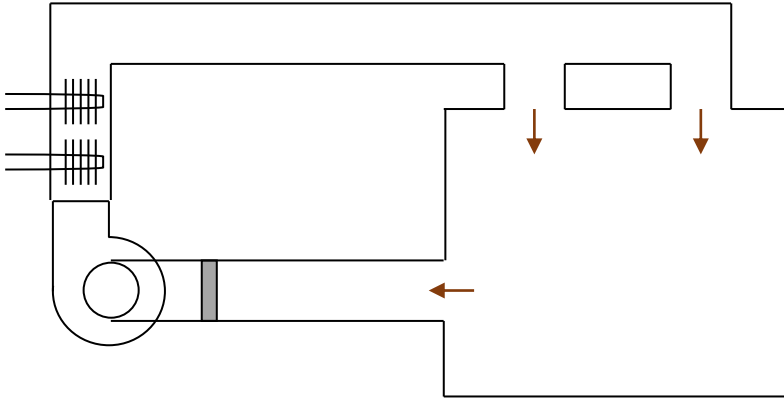

A particular duct system will produce a pressure drop (air flow resistance) which depends of the amount of air flow through that system. In general, the pressure drop is approximately proportional to the square of the airflow rate.

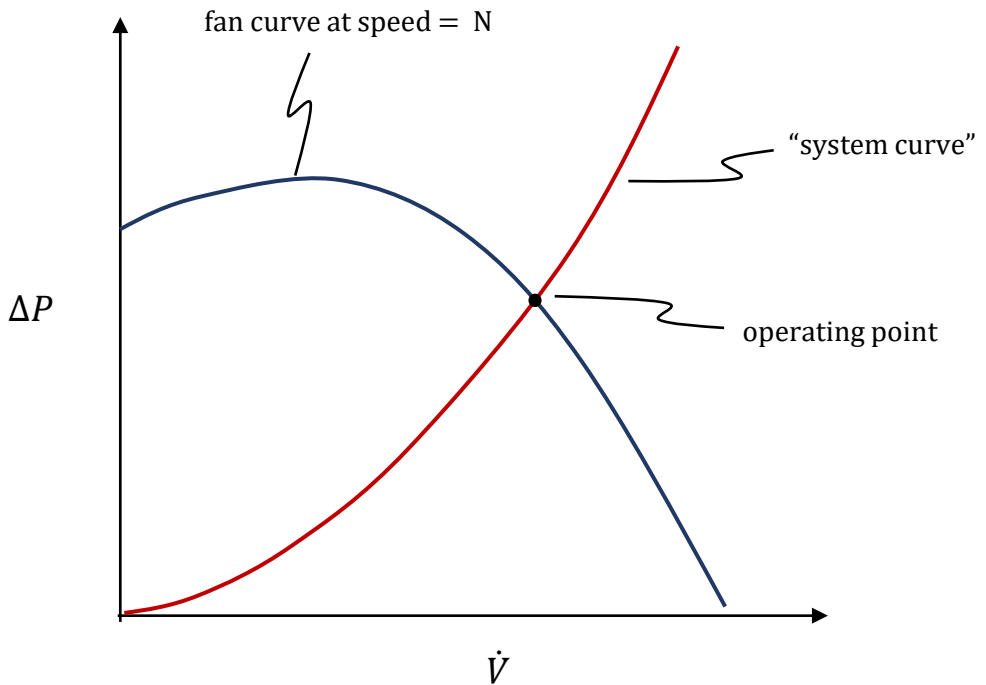

5. Fans Laws for Shaft-Speed Changes

The Fan Laws are simplified theoretical equations for predicting fan performance at differing operating conditions. If the performance is measured at one condition (e.g. speed), the equations can be used to predict the performance at another condition.

The Fan Laws include an assumption that η_f (fan efficiency) is constant—so the equations are useful only within a limited range of operation. They also assume that the duct system characteristics are unchanged (except flowrate and pressure drop) and the system behaves approximately as $\Delta P \propto \dot{V}^2$.

- N = shaft rotational speed (e.g. rpm or rad/s)
- \dot{V} = volumetric flowrate (e.g. cfm or m³/s)
- ΔP = pressure rise developed (e.g. in. w.g. or Pa)
- \dot{W}_{sh} = required shaft power input (e.g. hp or W)

in. w.g = inches
of water gauge

#1 - Volumetric Flow Rate:
$$\frac{\dot{V}_2}{\dot{V}_1} = \frac{N_2}{N_1}$$

#2 - Pressure Increase Provided:
$$\frac{\Delta P_2}{\Delta P_1} = \left(\frac{N_2}{N_1}\right)^2$$

#3 - Required Shaft Power:
$$\frac{\dot{W}_{sh2}}{\dot{W}_{sh1}} = \left(\frac{N_2}{N_1}\right)^3$$

Note: A simple means of achieving a permanent speed change is by changing diameter of pulleys on motor and fan shafts.

Pulley Equation: $D_f \cdot N_f = D_m \cdot N_m$

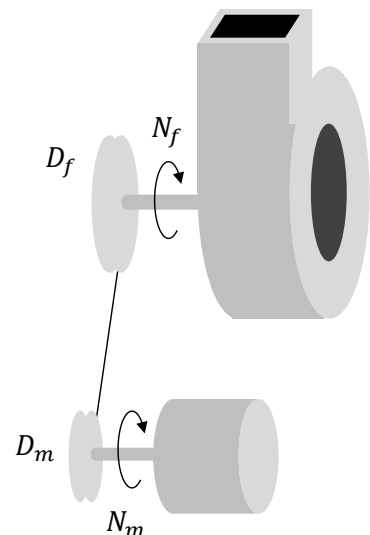

Example Calculation

When a fan is initially run at steady operation, the following values are determined:

shaft speed	= 850 rpm
air flow	= 1800 L/s
pressure rise	= 600 Pa
shaft power	= 2400 W

Apply the Fan Laws to estimate the performance parameters if the fan speed is increased until the flow is 2000 L/s.

Condition 1 (above):

$$\begin{aligned}N_1 &= 850 \text{ rpm} \\ \dot{V}_1 &= 1800 \text{ L/s} \\ \Delta P_1 &= 600 \text{ Pa} \\ \dot{W}_{sh1} &= 2400 \text{ W}\end{aligned}$$

Condition 2:

$$\dot{V}_2 = \mathbf{2000 \text{ L/s}}$$

$$N_2 = N_1 \left(\frac{\dot{V}_2}{\dot{V}_1} \right) = (850 \text{ rpm}) \left(\frac{2000 \text{ L/s}}{1800 \text{ L/s}} \right) = \mathbf{944 \text{ rpm}}$$

$$\Delta P_2 = \Delta P_1 \left(\frac{N_2}{N_1} \right)^2 = (600 \text{ Pa}) \left(\frac{944 \text{ rpm}}{850 \text{ rpm}} \right)^2 = \mathbf{740 \text{ Pa}}$$

$$\dot{W}_{sh2} = \dot{W}_{sh1} \left(\frac{N_2}{N_1} \right)^3 = (2400 \text{ W}) \left(\frac{944 \text{ rpm}}{850 \text{ rpm}} \right)^3 = \mathbf{3288 \text{ W}}$$

6. Electric Motors for HVAC Fans and Pumps

This discussion will be concerned with alternating current (AC), three-phase, induction motors (i.e. “squirrel cage” motors). This type of motor is commonly used in building HVAC equipment where motor size of ≈ 1 hp (0.75 kW) or larger is required.

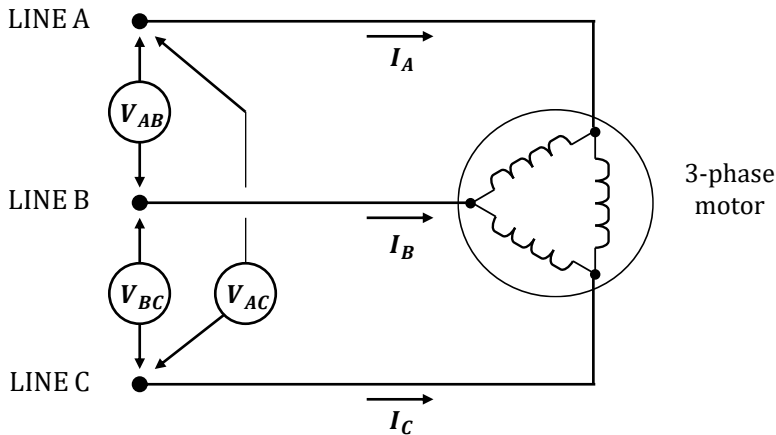

AC Induction Motors:

- The rotor lies within a magnetic field created by the stator windings. An electric current is induced within the rotor and the resulting force (torque) causes the rotor to turn.
- The rotational speed of the magnetic field is called the “Synchronous Speed”.
- During operation, the rotor spins at a speed (rpm) slightly slower than the synchronous speed. The difference between the synchronous speed and rotor speed is referred to as the “slip”.

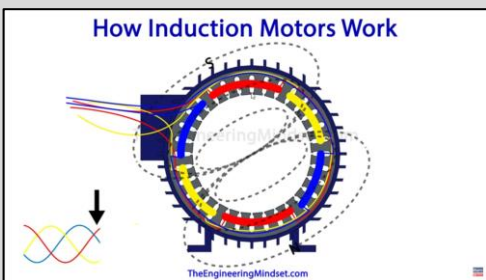

VIDEO:

Watch the following brief video about AC induction motors:

**“How does an induction motor work”
(11 mins)**

The Engineering Mindset, 2017.

<https://youtu.be/N7TZ4gm3aUg>

Terminology

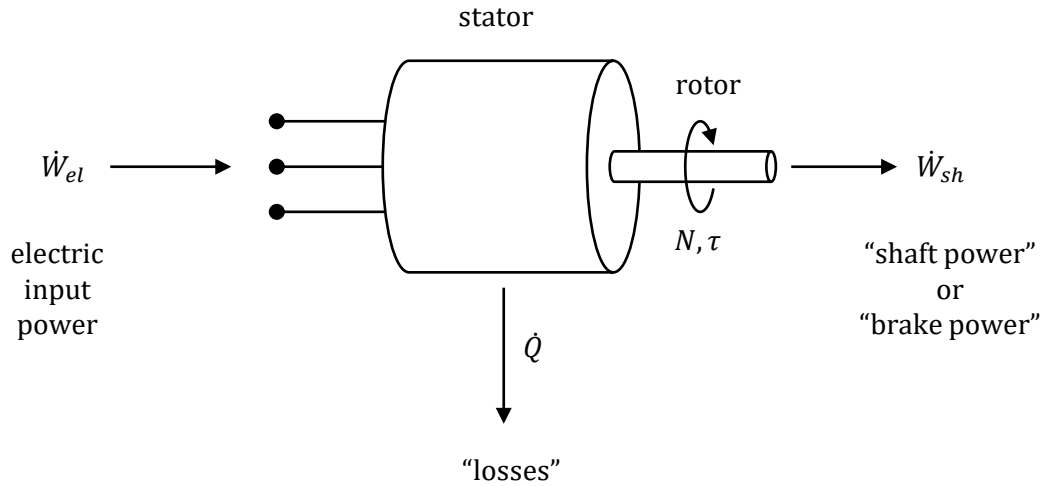

Metric Units: $N = \text{rotational speed (rad/s)}$

$\tau = \text{torque (N} \cdot \text{m)}$

$$\dot{W}_{sh} = \tau \cdot N \quad (W)$$

I-P Units: $rpm = \text{revolutions per minute}$

$\tau = \text{torque (ft} \cdot \text{lb)}$

$$\dot{W}_{sh} = \frac{\tau \cdot rpm}{5252} \quad (hp)$$

Conversion: 1 horsepower = 1 hp \approx 746 watts = 0.746 kW

The delivered shaft power might sometime be referred to as "brake power", "brake horsepower" (bhp), or mechanical power.

Rated Output

or

- Rated Power
- Motor Size
- Motor hp
- Motor kW
- Motor Capacity

All of these are equivalent terms referring to the nominal maximum output power that the motor can provide.

e.g. “10 hp motor” (or “7.5 kW motor”) refers to the motor’s nominal capacity.

Synchronous Speed, N_s

- Rotating speed of the magnetic field. Depends on construction of the stator (number of poles) and the frequency of the AC power supply to the motor. If the power frequency is constant, then synchronous speed is constant.

$$N_s = \frac{120 \cdot \text{frequency}}{\text{number of poles}}$$

At 60 Hz:

Poles	N_s (rpm)
2	3600
4	1800
6	1200
8	900

Rotor Speed, N (or simply “Speed”)

- Rotating speed of the rotor. Depends on synchronous speed and load.

Conversion:

$$1 \text{ revolution} = 2\pi \text{ radians}$$

$$1 \text{ rpm} = \frac{2\pi \text{ radians}}{60 \text{ s}} \approx 0.10472 \frac{\text{rad}}{\text{s}} \quad \rightarrow \quad 1 \text{ rpm} \approx 0.10472 \text{ rad/s}$$

e.g. $1750 \text{ rpm} \approx 183.3 \text{ rad/s}$

Motor Efficiency , η

$$\eta = \frac{\dot{W}_{sh}}{\dot{W}_{el}}$$

Efficiency is not fixed. It is impacted by operating conditions (including load).

Slip

- The rotor does not rotate at the synchronous speed but lags it slightly (i.e. rotor is slightly slower). The difference (in rad/s or rpm) is called the slip.

$$slip = N_s - N \qquad \% \text{ slip} = \left(\frac{N_s - N}{N_s} \right) \cdot 100\%$$

Torque-Speed Curve

- The figure below shows the typical shape of a torque-speed curve for a “NEMA Design B” induction motor—a motor type frequently used to drive HVAC fans and pumps.
- The horizontal axis indicates rotor speed as a percentage of the synchronous speed. The vertical axis indicates rotor torque as a percentage of “Full Load” torque.
- The “Full-Load Torque” indicates the nominal maximum torque that the motor is rated to deliver on a continuous basis (i.e. once it has started and reached its running speed).
- The motor’s “Rated Performance” is defined at the 100% Full Load Torque point or “Full Load Point” (FLP). At the FLP, the motor delivers 100% of its rated torque and the rotor speed is slightly less than the synchronous speed.

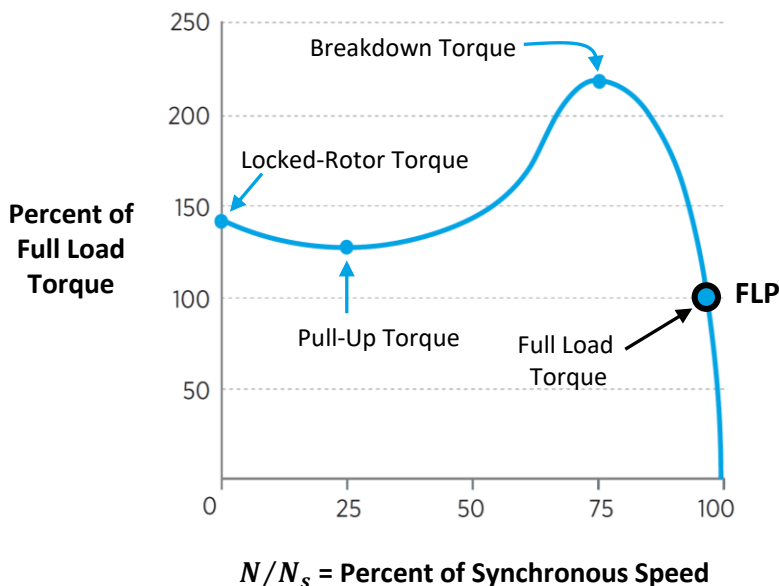

Adapted from Fig 5. (pg 11) in “Improving Motor and Drive System Performance” (US DOE)

Rated Performance

(or “Full Load Performance”)

- The motor’s operating characteristics when running steadily at the FLP are referred to as its “Rated Performance” or “Full-Load Performance” (or sometimes “Nameplate Performance”). When the motor is running at that condition, we say it is running at “full-load” or “100% load”. At that point, some key characteristics for energy analysis are:

$$\text{Rated Output} = \dot{W}_{sh,FL}$$

$$\text{Rated Speed} = N_{FL}$$

$$\text{Rated Efficiency} = \eta_{FL}$$

Example

Rated Output = **10 hp**

Rated Speed = **1750 rpm** ← rotor speed (not synchronous speed)

Rated Efficiency = **90%**

4-pole, 60 Hz (**1800 rpm synchronous speed**)

If this motor operates at full-load (i.e. at rated performance) then:

$$\dot{W}_{sh} = 10 \text{ hp} = 7460 \text{ W}$$

$$\begin{aligned} \dot{W}_{el} &= \dot{W}_{sh} / \eta = (7460 \text{ W}) / 0.9 \\ &= 8289 \text{ W} \end{aligned}$$

$$\dot{Q} = 8289 - 7460 \text{ W} = 829 \text{ W}$$

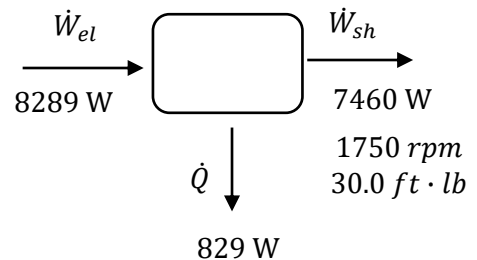

$$\tau = \frac{\dot{W}_{sh} \cdot 5252}{rpm} = \frac{(10) \cdot 5252}{(1750)} = 30.0 \text{ ft} \cdot \text{lb} \quad \leftarrow \text{i.e. Rated Torque}$$

$$\text{slip} = 1800 - 1750 = 50 \text{ rpm} \quad \leftarrow \text{i.e. "Full-Load Slip"}$$

7. Motor Speed and Shaft-Power at Part-Load

The Full Load Point (FLP) for a motor indicates its capacity. However, motors in HVAC systems typically operate at a load below their capacity.

A motor running at part-load means that it is delivering output power and torque below its rating even though the rotor has reached a steady running speed (which would be close to the synchronous speed). When running at part-load, the rotor's speed will be slightly higher than the rated speed. (The rotor speed will increase toward the synchronous speed as the load decreases—that is, the slip will approach zero as the load approaches zero.)

Note that the actual shaft power being delivered by a motor is sometimes referred to as the “brake power”.

On the Torque-Speed Curve, let's define the “Part-Load Region” to be the region between the FLP and the “Zero Load Point” (ZLP). (We can view the ZLP as representing a situation where the motor is powered but its shaft is not coupled to a load and is spinning freely.)

(Note: “RPP” and “ZLP” are terms being used for the sake of the present discussion. They are not industry terminology.)

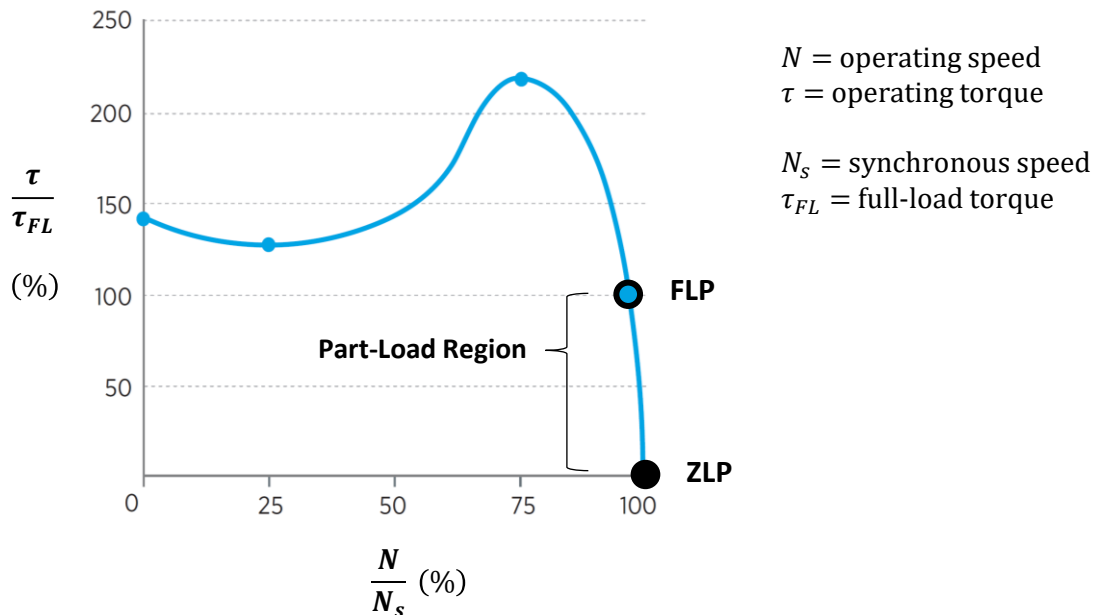

In the part-load region, the relative change in the value N/N_s is typically very small, moving from perhaps 97% at FLP to 100% at ZLP. In contrast, τ/τ_{FL} undergoes a dramatic change between those two points—from 100% at FLP to 0% at ZLP. Also, we should note that the shaft power would vary from its rated output value (at FLP) to zero at (ZLP) since $\dot{W}_{sh} = \tau \cdot N$.

At FLP: $N = N_{FL}$

$$\tau = \tau_{FL}$$

$$\dot{W}_{sh} = \dot{W}_{sh,FL} = \tau_{FL} \cdot N_{FL}$$

At ZLP: $N \approx N_s$

$$\tau = 0$$

$$\dot{W}_{sh} = 0$$

Since the relative change in the operating speed is very small in the part-load region, it is reasonable to approximate the torque and shaft power as being proportional to each other in this region. That is:

$$N \approx \text{constant} \approx N_s \quad (\text{running speed is very close to } N_s \text{ in the region})$$

At FLP: $\dot{W}_{sh} = \tau \cdot N = \tau_{FL} \cdot N_{FL} \approx \tau_{FL} \cdot N_s$

At ZLP: $\dot{W}_{sh} = \tau \cdot N = \tau_{ZL} \cdot N_s$

\therefore In this region: $\dot{W}_{sh} \propto \tau$ (i.e. shaft power is approximately proportional to torque)

Now, the speed change in the part-load region is not actually zero. But what is being inferred in the above discussion is that the relative speed change is very small in this region, and therefore the change in shaft power between FLP and ZLP is mostly due to the change in delivered torque.

Now let's consider the speed change from the perspective of slip, $N_s - N$. At ZLP, slip is approximately zero. At FLP, the slip is the full load slip.

At ZLP: $slip = N_s - N \approx 0$

At FLP: $slip_{FL} = N_s - N_{FL}$

Between FLP and ZLP, the slip varies from $slip_{FL}$ to 0, and we can say it varies from 100% of the full-load slip at FLP to 0% of the full-load slip at ZLP. In this region, the torque varies roughly linearly with the % of FL slip, from $\tau = \tau_{FL}$ at FLP to $\tau = 0$ at ZLP.

Now putting all of this information together for the part-load region...

Below the horizontal axis is the same as before, but we've "zoomed in" to focus just on the part-load region. Further, we've now shown a straight-line connecting FLP and ZLP, indicating that torque and shaft-power in this region vary linearly from the rated performance at FLP to zero at ZLP.

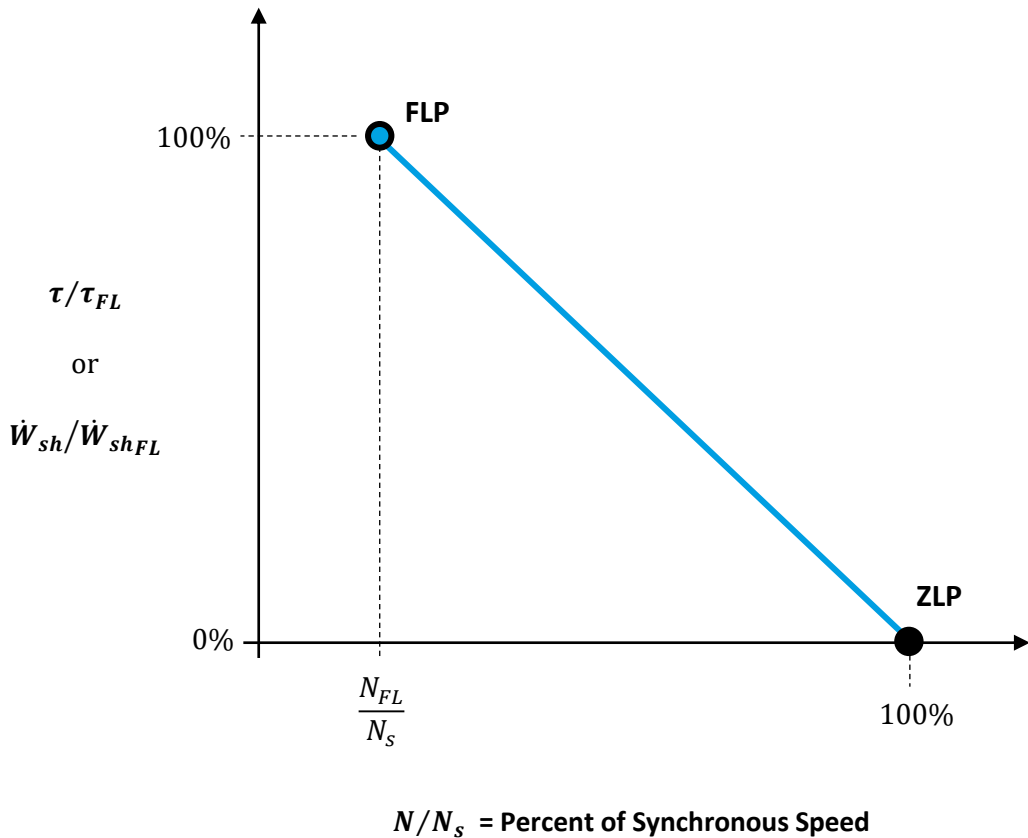

Now, at FLP the slip is "100% of the full-load slip" and at ZLP the slip is 0% of the full-load slip. So now let's transform the horizontal axis to indicate % of FL slip, which starts at 0% at ZLP and runs to 100% at FLP. The graph with this transformation is shown on the next page.

Note: All of the previous discussion is really meant just to get us to this graph...

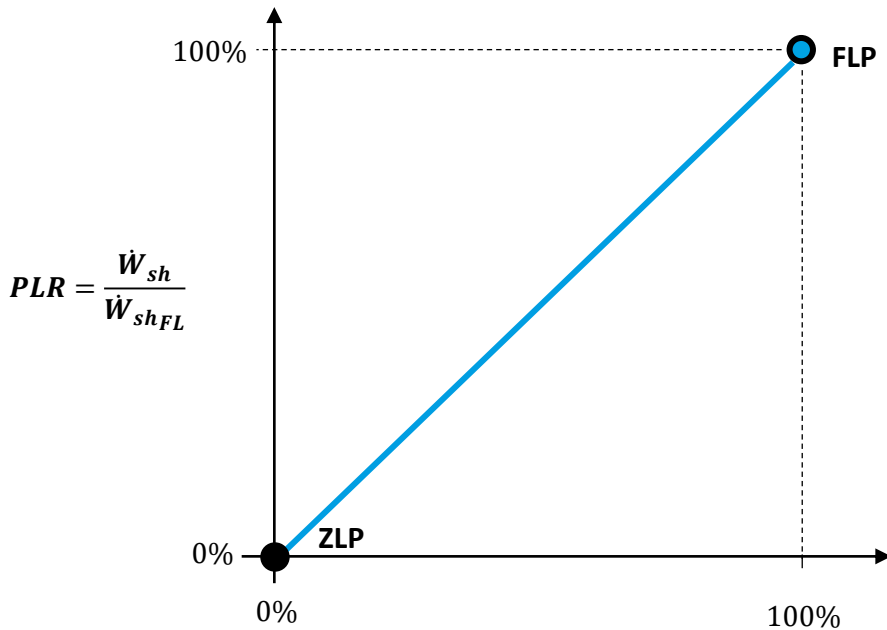

$$\% \text{ of FL slip} = \frac{\text{slip}}{\text{slip}_{FL}} = \frac{N_s - N}{N_s - N_{FL}}$$

For the motors under consideration: In the part-load region, it's a good approximation that the actual load relative to full-load output (capacity) is equal to the actual slip relative to full-load slip.

We can call the ratio indicated above on the vertical axis "Part-Load Ratio" (PLR) or % of full-load.

$$PLR = \frac{\text{load}}{\text{capacity}} = \frac{\text{required output}}{\text{equipment capacity}} = \frac{\dot{W}_{sh}}{\dot{W}_{sh_{FL}}}$$



General Definition
of "Part-Load Ratio"

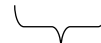

A specific definition of PLR for
the type of equipment currently
under consideration

For the motors being considered, we can say that in the part-load region:

$$PLR = \frac{\dot{W}_{sh}}{\dot{W}_{sh_{FL}}} = \frac{slip}{slip_{FL}}$$

$$\dot{W}_{sh} = \dot{W}_{sh_{FL}} \cdot \frac{N_s - N}{N_s - N_{FL}}$$

Thus, if we know a particular motor's size ($\dot{W}_{sh_{FL}}$), rated speed (N_{FL}), and synchronous speed (N_s) then we should be able to make an estimate the load on the motor with a tachometer measurement (i.e. N).

Example:

Rated Output = 10 hp, Rated Speed = 1750 rpm, Synchronous Speed = 1800 rpm

Actual Speed = 1765 rpm

$$\dot{W}_{sh_{FL}} = 10 \text{ hp}$$

$$N_s = 1800 \text{ rpm}$$

$$N_{FL} = 1750 \text{ rpm}$$

$$N = 1765 \text{ rpm}$$

$$slip_{FL} = 1800 - 1750 = 50 \text{ rpm}$$

$$slip = 1800 - 1765 = 35 \text{ rpm}$$

$$PLR = 35/50 = 70\%$$

$$\dot{W}_{sh} = \dot{W}_{sh_{FL}} \cdot PLR = \mathbf{7 \text{ hp}}$$

8. Motor Efficiency at Part-Load

The efficiency of induction motors varies with load. The graph below indicates typical efficiency curves, with the horizontal axis the PLR (% of FL) and the vertical axis the relative efficiency at part-load (η/η_{FL}).

For larger motors (10+ hp), as load is reduced from 100% the efficiency may initially increase slightly but will then generally decrease as PLR drops below about 50%. For smaller motors (≈ 1 hp), the decrease in efficiency begins sooner. Drastically oversized motors may operate at efficiency much lower than their rated efficiency.

Often the performance data for a specific motor will indicate operating efficiency at several different load levels (e.g. 100%, 75%, 50%, 25%). In that case, the efficiency can be estimated directly using that data (i.e. rather than a generic curve).

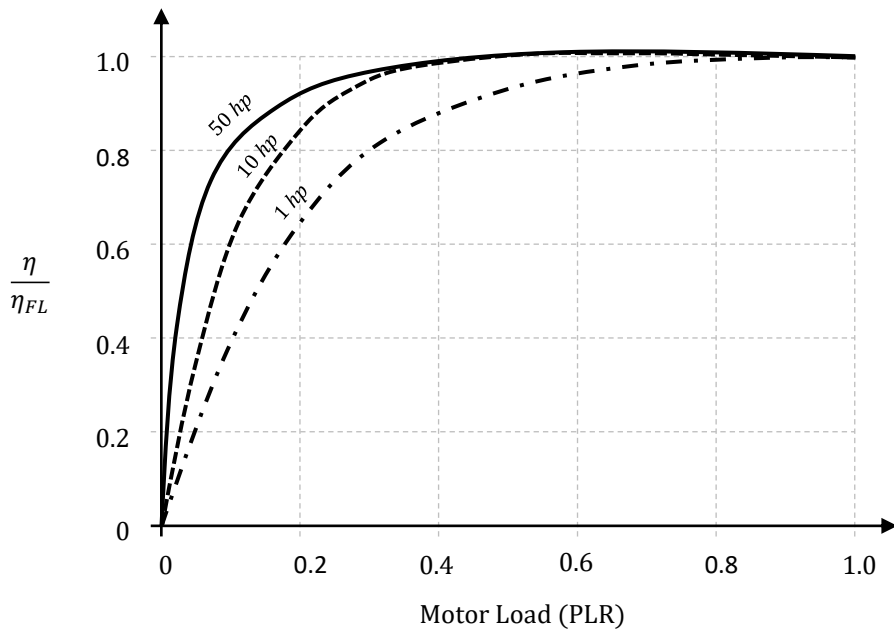

Example:

Determine input power (W) for a 1 hp motor with $\eta_{FL} = 80\%$ if $PLR = 20\%$. Estimate the part load performance using the graph above.

From the curve, at $PLR = 0.2$, $\eta/\eta_{FL} \approx 0.65$ (visual estimate).

$$\therefore \eta = \left(\frac{\eta}{\eta_{FL}} \right) \cdot \eta_{FL} = (0.65)(80\%) = 52\%$$

$$\dot{W}_{sh} = PLR \cdot \dot{W}_{sh_{FL}} = 0.2 \cdot (1 \text{ hp}) = 0.2 \text{ hp} = 149.2 \text{ W}$$

$$\dot{W}_{el} = \dot{W}_{sh}/\eta = 149.2 \text{ W}/0.52 = \mathbf{286.9 \text{ W}}$$

9. Fan & Motor Installed in a Duct System

Let's now consider a fan driven by a "directly-coupled" motor, and the pair installed to operate in a particular duct system.

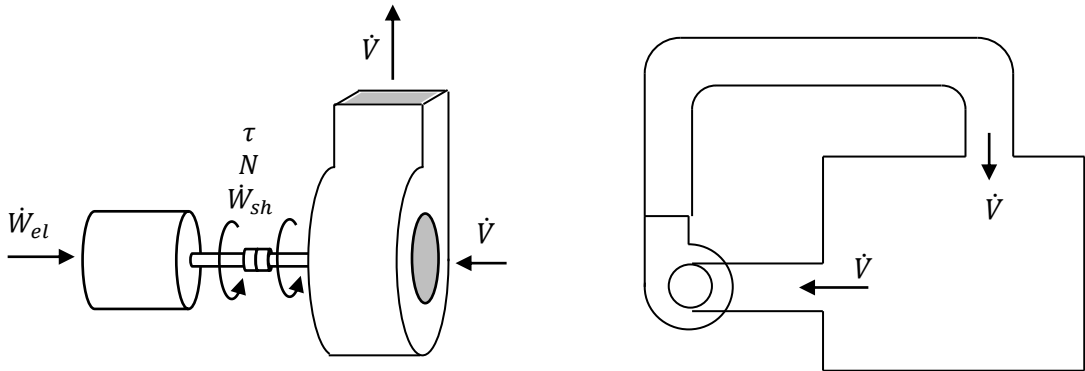

With the motor and fan shafts are directly-coupled—assuming the coupling is secure, so there's no slippage—the two shafts will effectively act as a one. That is, both devices will have the same rotational speed, the torque delivered by the motor will be the torque received by the fan, and the shaft power produced by the motor will be the shaft power delivered to the fan.

For a moment let's consider just the operation of the fan in the duct system. Say we're able to measure the performance of the fan when it's installed in the duct system and the following is determined:

With the fan driven at 1750 rpm , the required shaft power is $\dot{W}_{sh} = 1800 \text{ W}$, the flow is $\dot{V} = 1100 \text{ L/s}$, and the pressure difference across the fan is $\Delta P = 900 \text{ Pa}$.

From this information, we can infer the fan efficiency at this operating condition:

$$\eta_f = \frac{\Delta P \cdot \dot{V}}{\dot{W}_{sh}} = \frac{(900 \text{ Pa}) \cdot (1.1 \text{ m}^3/\text{s})}{(1800 \text{ W})} = \frac{990 \text{ W}}{1800 \text{ W}} = 55\%$$

Knowing this information, we could use the Fan Laws to estimate the performance for slight changes in fan speed. The known operating point is:

$$\begin{aligned} \text{At } N_1 = 1750 \text{ rpm:} \quad & \dot{V}_1 = 1.1 \text{ m}^3/\text{s} \\ & \Delta P_1 = 900 \text{ Pa} \\ & \dot{W}_{sh,1} = 1800 \text{ W} \end{aligned}$$

Let's now say we wish to adjust the fan speed such to make the flow $1.0 \text{ m}^3/\text{s}$. Apply the the Fan Laws to estimate the required shaft speed and power:

$$\text{Fan Law \#1: } N_2 = N_1 \cdot \frac{\dot{V}_2}{\dot{V}_1} = (1750 \text{ rpm}) \cdot \left(\frac{1.0 \text{ m}^3/\text{s}}{1.1 \text{ m}^3/\text{s}} \right) = \mathbf{1591 \text{ rpm}}$$

$$\text{Fan Law \#3: } \dot{W}_{sh,2} = \dot{W}_{sh,1} \cdot \left(\frac{N_2}{N_1} \right)^3 = (1800 \text{ W}) \left(\frac{1591 \text{ rpm}}{1750 \text{ rpm}} \right)^3 = \mathbf{1350 \text{ W}}$$

Or, say we'd like to know the flow and shaft power if the fan was driven at 1800 rpm.

$$\text{Fan Law \#1: } \dot{V}_2 = \dot{V}_1 \cdot \frac{N_2}{N_1} = (1.1 \text{ m}^3/\text{s}) \cdot \left(\frac{1800 \text{ rpm}}{1750 \text{ rpm}} \right) = \mathbf{1.13 \text{ m}^3/\text{s}}$$

$$\text{Fan Law \#3: } \dot{W}_{sh,2} = \dot{W}_{sh,1} \cdot \left(\frac{N_2}{N_1} \right)^3 = (1800 \text{ W}) \left(\frac{1800 \text{ rpm}}{1750 \text{ rpm}} \right)^3 = \mathbf{1959 \text{ W}}$$

The Fan Laws could be used to estimate the required shaft power at any speed near the known operating point (1750 rpm). The graph below plots the required fan shaft power versus speed over the range 1700 to 1800 rpm. (Note: In the range shown, the line may appear to be a straight line, but it is the cubic equation indicated.)

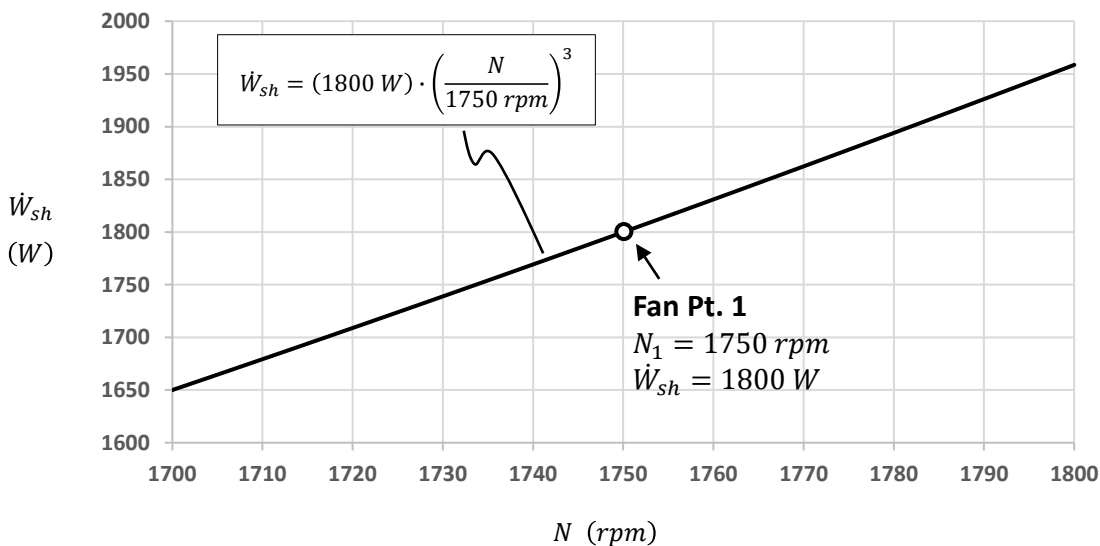

Now let's consider how the full system will operate when a particular motor is used. Assume the motor (to be coupled to the fan) has the characteristics indicated below:

Synchronous Speed = 1800 rpm
 Size = "3 hp"
 Rated Speed = 1725 rpm
 Rated Torque = 9.0 ft-lbs

Efficiency: { Full Load = 86.6%
 75% Load = 87.7%
 50% Load = 86.9%
 25% Load = 81.4%

Based on the rated speed and torque, the full load power is:

$$\dot{W}_{sh,FL} = \frac{\tau_{FL} \cdot rpm_{FL}}{5252} = \frac{(9) \cdot (1725)}{5252} = 2.956 \text{ hp} = 2205 \text{ W}$$

Below is a plot showing both fan power and motor power versus speed. The point of intersection indicates the running speed at which the power delivered by the motor would match that required by the fan—this is the predicted operating point.

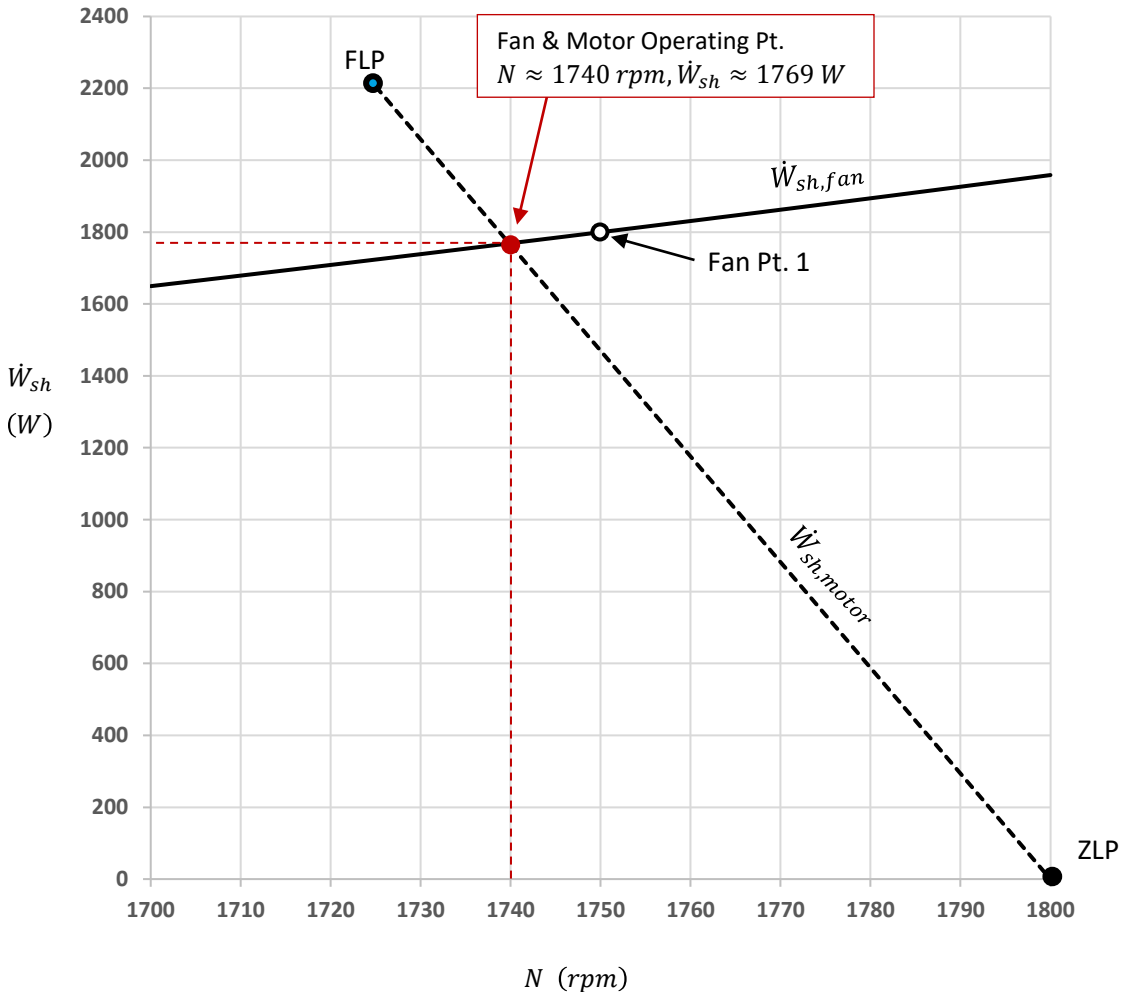

At the predicted operating point the delivers $\dot{W}_{sh} \approx 1760 W$, and so it's PLR can be calculated:

$$PLR = \frac{\dot{W}_{sh}}{\dot{W}_{sh_{FL}}} = \frac{1769 W}{2205 W} \approx 80\%$$

Now the motor efficiency can be estimated. By linear interpolation between the efficiency ratings provided at 75% and 100% load, the estimated efficiency at PLR = 80% is:

$$\eta \approx 87.5\%$$

So, the input power to the motor is:

$$\dot{W}_{el} = \dot{W}_{sh}/\eta = 1769 W/0.875 = \mathbf{2022 W}$$

Also, the flowrate of the fan running at 1740 rpm is:

$$\dot{V}_2 = \dot{V}_1 \cdot \frac{N_2}{N_1} = (1.1 m^3/s) \cdot \left(\frac{1740 rpm}{1750 rpm} \right) \approx \mathbf{1.093 m^3/s}$$

10. Simple Hydronic Heating System

The diagram below is a simplified depiction of a hydronic heating system provides heat for three thermal zones. Hot water “produced” by a boiler is circulated to a heat emitter (e.g. radiator) located in each of the three zones. The thermostat in each zone provides a signal to a control valve. When the room requires heat, the valve directs water flow through the radiator (i.e. “turn heat on”). When heat is not needed, the valve switches its position to bypass the radiator (i.e. “turn heat off”). The boiler is fired (as needed) to maintain a steady supply temperature in the circulating water loop.

Consider the similarity of the system depicted below to the “heated tank” system that has previously been considered. In the system below, it is as if the heat loss of the tank can be controlled (i.e. via the control value) and this “lost heat” directed to intended locations (i.e. Zones 1, 2, and 3).

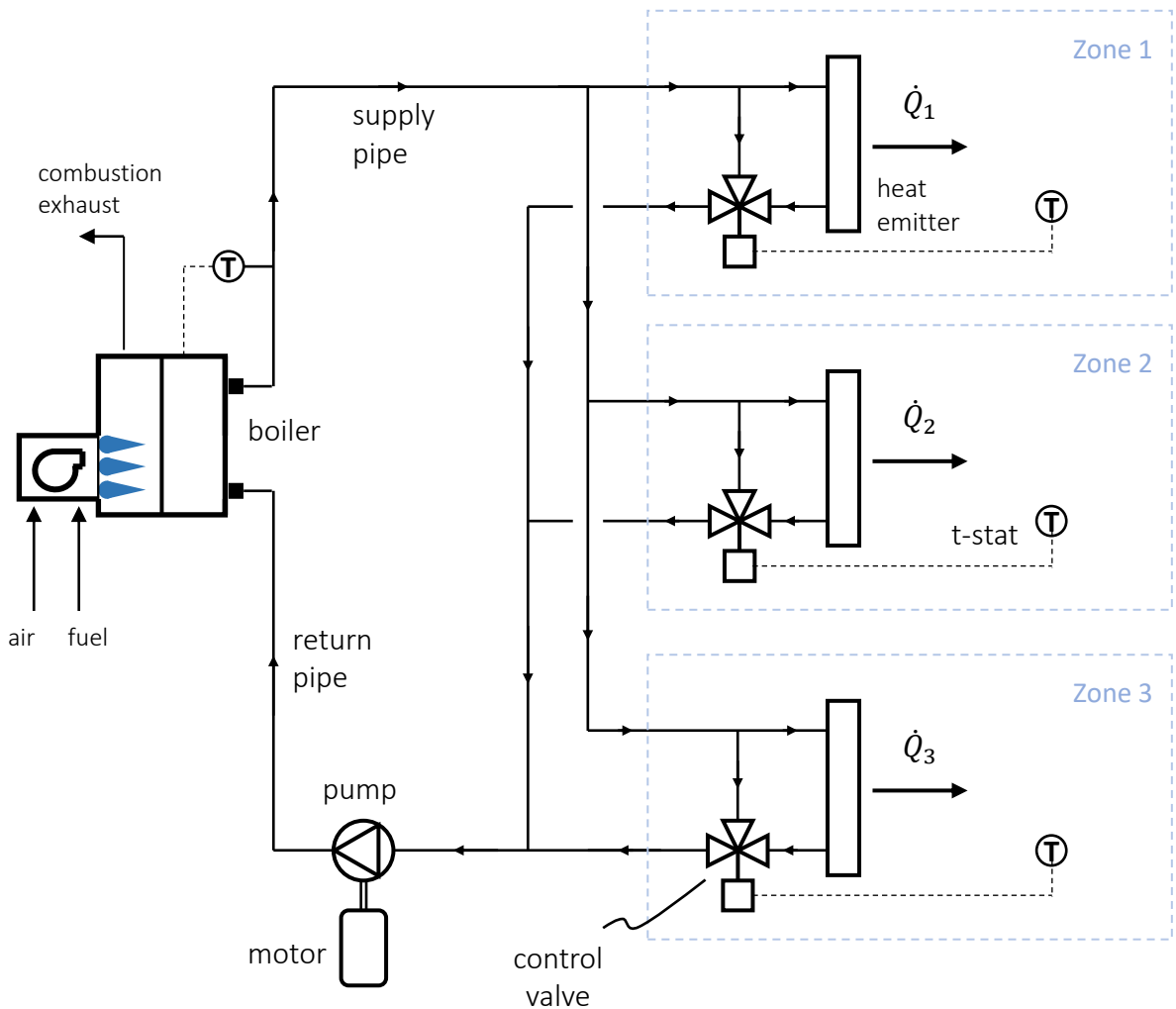

In a boiler, the key components of interest are the heat exchanger and the burner. A simplified depiction is provided below.

In most modern boilers, the movement of combustion gases through the combustion side of the heat exchanger will typically be forced/induced by a fan system. However, some boilers use “natural draft” (buoyancy-induced flow) on the combustion side.

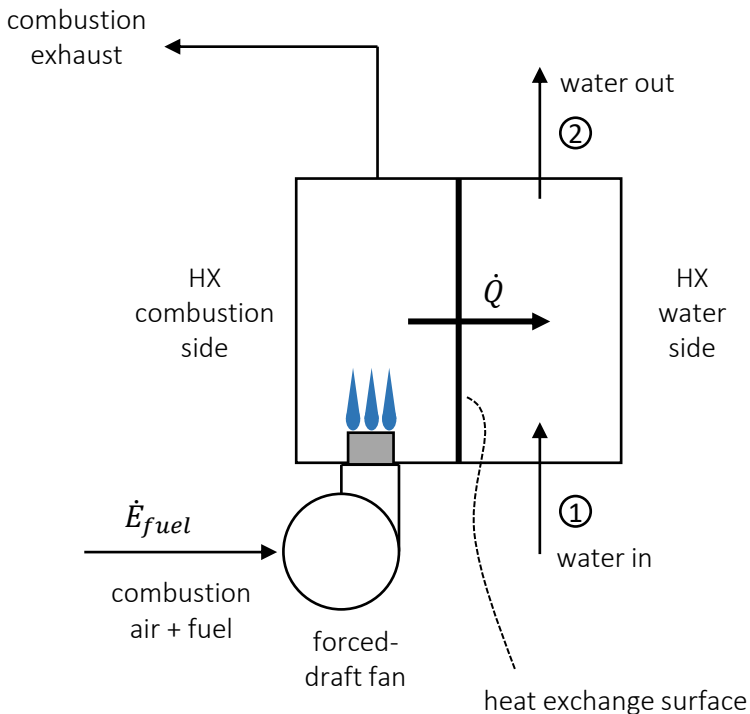

Note: “Boiler” is a generic term applied to devices used to heat water even when the water does not actually boil. A boiler might be described as a “hot water boiler” or “steam boiler” depending on its use.

11. Space Heating Boilers

The content in this section is intended to help you to gain some practical knowledge of space heating boilers. During a regular on-campus term, there would be a lab session that includes a “boiler dissection” (tear down). Because that isn’t possible during Fall 2020, this section provides several videos links and other information as alternatives.



Video by Viessmann:

Vitodens 100 W B1HA –
Space Heating Boiler (6 mins)

<https://youtu.be/zz5WQDbQz4Y>

Please watch the video. (If you’re interested, the link below will provide access to the technical data on the boiler discussed in the video. But visiting the link is optional.)

Product Information
Cross-Section

Legend

- (A) Stainless steel cylinder burner
- (B) Inox-Radial stainless steel heat exchanger
- (C) Burner blower
- (D) Natural gas and hydronic connections
- (E) Boiler control

Product may not look exactly as illustrated.

VIESSMANN

VITODENS 100-W

Natural gas-fired wall-mounted condensing boiler
29 to 100 MBH/8.6 to 29.3 kW

Technical Data Manual
Model Nos. and pricing: see Price List

Vitodens 100-W, WB1A
(with pre-installed coaxial vent pipe adapter)

Vitodens 100-W

WB1A Series

Natural Gas-Fired Wall-Mounted Condensing Boiler with modulating stainless steel natural gas cylinder burner and stainless steel inox-radial heat exchanger for room air. Independent operation using a direct vent system and room air dependent operation.

⚠ For Natural Gas only!

5347 965 v1.1 10/2007

<https://www.viessmann.ca/en/residential/gas-boilers/condensing-boilers/vitodens-100-b1ka.html>



Video by Tec Tube:

Boiler Types: Standard vs. High Efficiency
(10 mins)

<https://youtu.be/hWbGG26LvIs>

Residential Cast-Iron Boiler (oil fired)



Cabinet panels installed and combustion chamber door closed.



Cabinet panels removed and combustion chamber door open. (With the panels off, it's really just a big hunk of iron, i.e. the heat exchanger.)

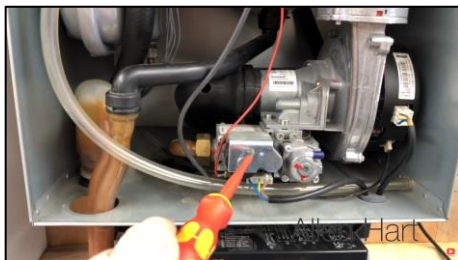

Video by Allen Hart:

Viessmann Vitodens 100 –
Whats Inside - Full Strip Down
(9 mins)

<https://youtu.be/zmcyOwhdPDs>

Want *more* boiler videos?

From “TheWXTV” (Weatherization TV):

Boiler Basics: Part I - Combustion Air and Drafting

15 mins

<https://youtu.be/sOp6LiG7ncY>

Boiler Basics: Part II - Clean, Test, & Tune

15 mins

<https://youtu.be/ZnsShrdZqgA>

Boiler Basics: Part III - External Components

11 mins

<https://youtu.be/3NVZFAcqDOK>

12. Seasonal Boiler Efficiency

Recall the general definition of efficiency: $\eta = \frac{\text{output}}{\text{input}}$

This may be assessed on an instantaneous basis or over a finite-time period:

$$\eta(t) = \frac{\dot{E}_{out}(t)}{\dot{E}_{in}(t)} \qquad \eta_{avg} = \frac{\int \dot{E}_{out}(t) \cdot dt}{\int \dot{E}_{in}(t) \cdot dt}$$

The information provided below and on the following page are extracts from:

*“CIBSE Guide B: Heating, Ventilating, Air Conditioning and Refrigeration”
The Chartered Institution of Building Services Engineers London, 2005.*

1.4.2.3 Seasonal boiler efficiency

Boiler efficiency is the principal determinant of system efficiency in many heating systems. What matters is the average efficiency of the boiler under varying conditions throughout the year, known as ‘seasonal efficiency’. This may differ significantly from the bench test boiler efficiency, although the latter may be a useful basis for comparison between boilers. Typical seasonal efficiencies for various types of boiler are given in Table 1.7. For domestic boilers, seasonal efficiencies may be obtained from the SEDBUK⁽⁵²⁾ database.

Many boilers have a lower efficiency when operating at part load, particularly in an on/off control mode, see Figure 1.4. Apart from the pre-heat period, a boiler spends most of its operating life at part load. This has led to the increased popularity of multiple boiler systems since, at 25% of design load, it is better to have 25% of a number of small boilers operating at full output, rather than one large boiler operating at 25% output.

Condensing boilers operate at peak efficiency when return water temperatures are low, which increases the extent to which condensation takes place. This can occur either at part or full load and depends principally on the characteristics of the system in which it is installed. Condensing boilers are particularly well suited to LPHW systems operating at low flow and return temperatures, such as under-floor heating. They may also be operated as lead boilers in multiple boiler systems.

(cont’d)

Table 1.7 Typical seasonal efficiencies for various boiler types⁽¹²⁾

Boiler/system	Seasonal efficiency / %
Condensing boilers:	
— under-floor or warm water system	90
— standard size radiators, variable temperature circuit (weather compensation)	87
— standard fixed temperature emitters (83/72 °C flow/return)*	85
Non-condensing boilers:	
— modern high-efficiency non-condensing boilers	80–82
— good modern boiler design closely matched to demand	75
— typical good existing boiler	70
— typical existing oversized boiler (atmospheric, cast-iron sectional)	45–65

* Not permitted by current Building Regulations

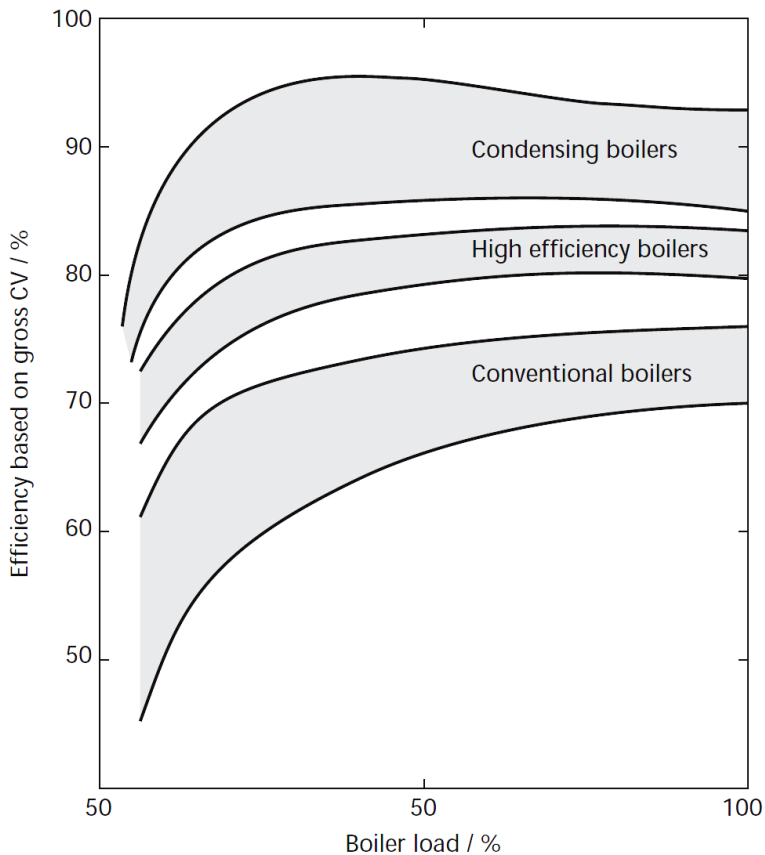

Figure 1.4 Typical seasonal LTHW boiler efficiencies at part load⁽⁵³⁾