

User Guide for Simulations

Fostering Authentic Inclusion and Accessibility

For an electronic version of this user guide please visit:
<https://sites.google.com/view/user-guide-for-vr-simulations/home>

User Guide for Simulations

Fostering Authentic Inclusion and Accessibility

Note On Language:

This guide uses a mix of both identity-first language (e.g., disabled student) and person-first language (student with a disability). Individuals will have their own preferences when it comes to identity-first and person-first language. Similarly, some people may not identify with the language of disability or feel that it applies to them. Mirroring the language individuals use to describe themselves and asking about their preferences is generally best.

Source: <https://accessibilityhub.niagaracollege.ca/>

Debrief

Before you begin, you should know that after each scenario, your instructor will facilitate a “debrief” with the group. This will involve a class discussion using some of the questions listed below. We are providing some of the possible questions you will be asked to reflect upon in advance so you can be mindful of them during the simulation and/or if you finish the simulation before others.

What?

- What aspects of the scenario worked for you as a learner? What stood out as memorable?
- What surprised you about the scenario? How did this surprise help? Hinder your learning? How did it enhance or detract from the experience?
- What emotions did you experience during the scenario?

So What?

- So, what does it mean for you to have felt the emotions that you did?
- What opportunities for reflection on your own awareness have opened up for you?

Now What?

- What information are you taking away that you think is important for you as you move forward into more interactions with disabled people?

User Guide for Simulations

Fostering Authentic Inclusion and Accessibility

Summary

These immersive simulations give users a window into the lives of people with disabilities to raise awareness about ableist interactions, and to learn about appropriate responses and strategies for challenging ableism. The simulations highlight assumptions and systemic barriers that many individuals with disabilities encounter in their daily lives.

The simulations, designed in consultation with the Advisory Council for Brock-Niagara Centre of Excellence in Inclusive and Adaptive Physical Activity, depict real lived experiences of individuals with disabilities that happen on post-secondary campuses.

You will participate in 4 individual conversations that each discuss important topics about inclusion and accessibility on a post-secondary campus. In each of the scenarios, you will take on a different role.

- Scenario 1 involves peer advice for an enrolled student with a concussion.
- Scenario 2 is a professor working with a student with disabilities who has a letter of accommodation.
- Scenario 3 is a student with a disability interfacing with a parking administrator when they have difficulties parking their vehicle.
- Scenario 4 is a student with a disability who is called to the Campus Security office to discuss an incident report.

Recommendations

1. It is recommended that you play each scenario more than once, choosing different options to explore different outcomes. These VR simulations provide a safe space to explore options (conversations) that you might not otherwise engage in. So, feel free to choose atypical responses.
2. Should you experience nausea, disorientation, eye strain or headache (these are common with [VR motion sickness](#)), we advise you take a break or switch to the PC version of these simulations.

Content Warning

Some of these simulations depict situations that may be sensitive in nature to some users. You will encounter examples of ableist interactions and barriers to accessibility that have been scripted from the real lived experiences of individuals with disabilities. These may cause upset or distress for some users.

User Guide for Simulations

Fostering Authentic Inclusion and Accessibility

First Steps: Using VR Goggles

Before you begin the simulations, make sure you review the instructional video on how to use the VR goggles. Your instructor may preview this video with the class before you begin the simulation or you can view it independently at [instructional videos](#).

Simulation Controls for PC

NOTE: A PC version of the simulations is available for those who may: experience VR motion sickness; wear glasses; have accessibility issues that may limit or prevent the use of simulation goggles and/or hand controls; or choose PC as a personal preference.

Table 1: Guide to the PC Controls for Specific Actions in the Simulation

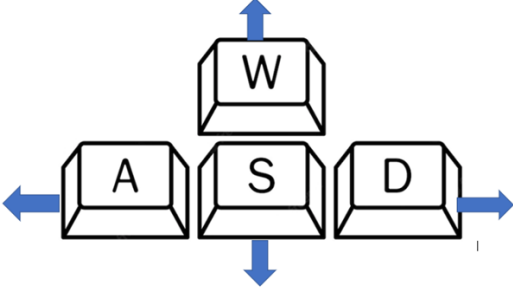
ACTION	PC CONTROL
Interact (with object)	Left click on highlighted object
Interact (with User Interface buttons)	Left click on User Interface
Movement	<p>WASD- Four keyboard keys that are used to interact with video games in lieu of arrow keys or a controller. W and S control forward and backward movement, while A and D are left and right.</p>  <p>The diagram shows four keyboard keys arranged in a cross shape. The 'W' key is at the top, 'S' is at the bottom, 'A' is on the left, and 'D' is on the right. Blue arrows point from each key in its respective cardinal direction: up from W, down from S, left from A, and right from D.</p>

Simulation Controls for VR

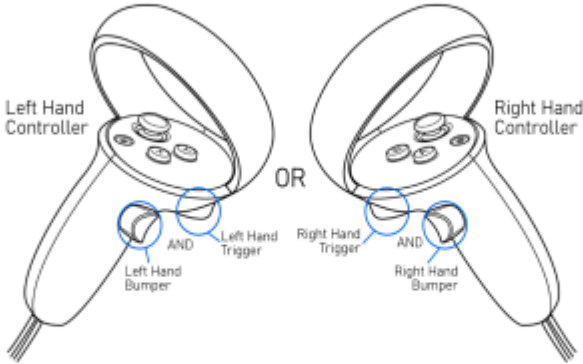
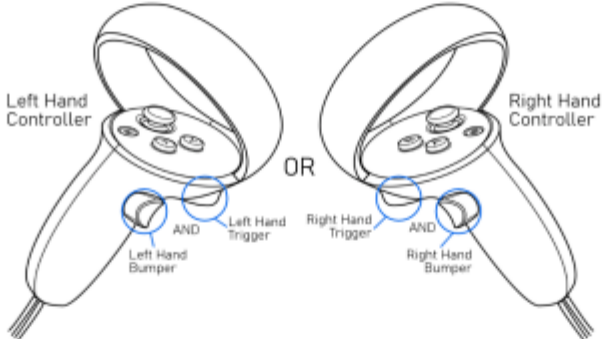
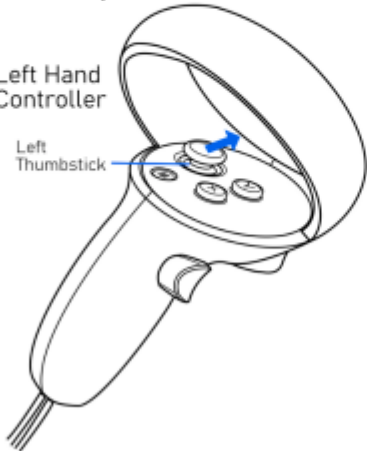
ACTION	VR CONTROL
Interact (with object)	<p>Tapping the Left-Hand or Right-hand bumper (middle finger) activates the laser pointer, hover over highlighted object.</p>  <p>The diagram illustrates two VR controllers side-by-side. On the left is the 'Left Hand Controller' and on the right is the 'Right Hand Controller'. Between them is the word 'OR'. Blue circles highlight specific buttons on each controller: the 'Left Hand Bumper' and 'Right Hand Bumper' (both labeled 'AND'), and the 'Left Hand Trigger' and 'Right Hand Trigger' (both labeled 'AND').</p>
Interact (with User Interface buttons)	<p>Left-Hand or Right-hand trigger (index finger) on User Interface</p>  <p>This diagram is identical to the one above, showing the 'Left Hand Controller' and 'Right Hand Controller' with callouts for 'Left Hand Bumper', 'AND', 'Left Hand Trigger', 'Right Hand Trigger', 'AND', and 'Right Hand Bumper'.</p>
Movement	<p>Left-Hand or Right-hand Thumbstick up, and release when pleased with the indicator position</p>  <p>The diagram shows a 'Left Hand Controller' with a blue arrow pointing to the 'Left Thumbstick'.</p>

To Begin

Enter your name and school/ institutional email. A transcript of the conversation will be sent to this address. Adjust settings as needed, using the tab located in the top right corner of your screen. Then, select START to begin.

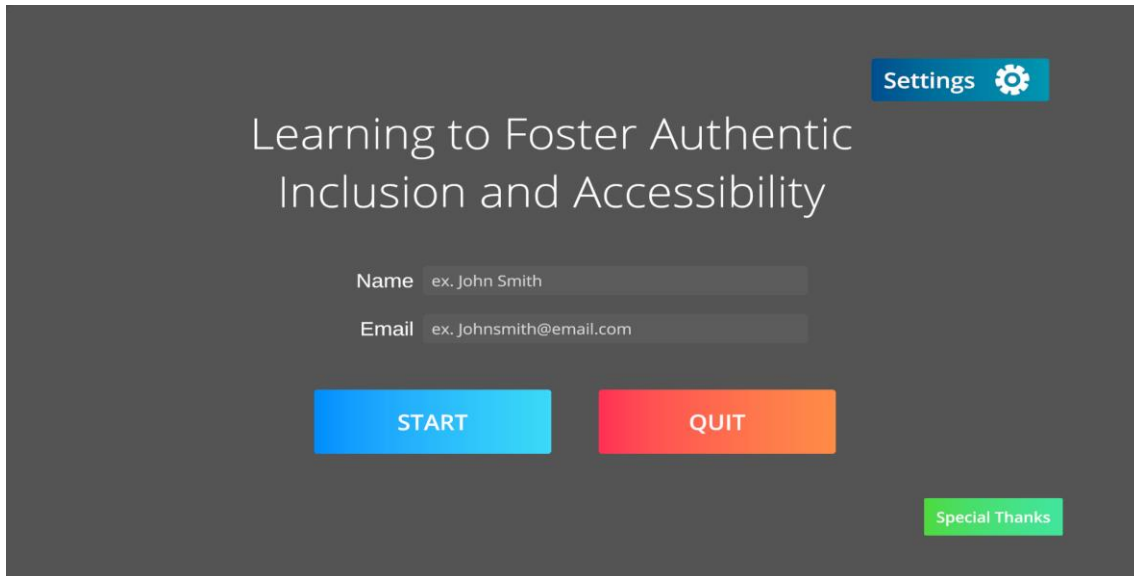

Settings 

Learning to Foster Authentic Inclusion and Accessibility

Name

Email

START **QUIT**

Special Thanks

Settings for Accessibility

Under the settings tab located in the top right corner of your start screen, you will have the following options to choose from: Magnification Lens; Text Augmentation (options include bolded and text size); Text Colour; Text to Speech; Object Description; Object Recolouring; Master Volume, Voices Volume, and Sound Effects.



Magnification Lens	Magnification Level: <input type="button" value="←"/> 1 <input type="button" value="→"/>	<input type="radio"/> OFF
Text Augmentation	Bolded: <input checked="" type="checkbox"/> ON Text Size: <input type="button" value="Small"/> <input type="button" value="Medium"/> <input type="button" value="Large"/>	<input type="radio"/> OFF
Text Colour	Colour: <input type="button" value="Yellow"/> <input type="button" value="Green"/> <input type="button" value="Blue"/>	<input type="radio"/> OFF
Text to Speech		<input checked="" type="radio"/> ON
Object Description		<input type="radio"/> OFF
Object Recolouring		<input type="radio"/> OFF
Master Volume	<input type="button" value="←"/> 5 <input type="button" value="→"/>	
Voices Volume	<input type="button" value="←"/> 5 <input type="button" value="→"/>	
Sound Effects	<input type="button" value="←"/> 5 <input type="button" value="→"/>	

Four Scenarios

SCENARIO SELECTION: There are 4 different scenarios and as the user, you can take on a different role in each of these. It is recommended that you play each scenario more than once, choosing different options to explore different outcomes. Select "ALL SCENARIOS" to do so, the next scenario will automatically begin when the previous one is finished. Selecting the circle on any scenario (you may choose more than one) will let you play the selected ones when you press the START button at the bottom.



Use the settings tab located in the top right corner of your start screen to adjust magnification, text colour and size, object recolouring or volume. You can also turn speech-to-text and object-description features off or on.

SCENARIO OUTLINES

Scenario 1: Impact of Concussion on Continuing a Course

OVERVIEW: You are in the position of someone who recently received a concussion diagnosis after a skiing accident. You are at the café with your friend Emma who had a similar concussive injury last year when you were in 1st year. You are in week 6 of a 14-week term in post-secondary education. Participate in a conversation about what might be the next best steps in these circumstances.



1. Enter the scenario and click "Begin" on the overview.
2. Complete the rest of the conversation with Emma as you see fit.
3. Emma appears for a debrief of the scenario after the conversation is complete.
4. Simulations done in a classroom setting will pause between scenarios for class debrief.

Scenario 2: Meeting New Student with Academic Accommodations

OVERVIEW: You are a professor at the college and a student is stopping by your office. The student, Alex, has a Letter of Accommodation that they want to discuss with you. Alex also has some questions about how best they can succeed in the course.



1. Enter the scenario and click "Begin" on the overview.
2. Complete the conversation with Alex as you see fit.
3. Alex appears for a debrief of the scenario after the conversation is complete.
4. Classroom debrief.

SCENARIO 2: ARTIFACTS

There are two scenario artifacts in this simulation.

1. **Artifact 1:** The first is a student's Letter of Accommodation.
2. **Artifact 2:** The second is the student view of this letter of Accommodation.

SCENARIO 2- ARTIFACT 1: STUDENT'S LETTER OF ACCOMMODATION

MEMORANDUM

Health, Wellness and Accessibility Services

Letter of Accommodation

FROM: LOA Provider

RE: Academic Accommodations for Alex

The above-named student is registered with the Health, Wellness and Accessibility Services office. Our office operates under the guidelines set both by the Accommodation Policy and the Human Rights Code.

Presently this student has the following special circumstances:

- Uses an FM system. This is a wireless amplification system that involves the instructor wearing a small microphone. The instructions are transmitted directly to the student's ear through a specially designed receiver.

Based on our review of the student's documentation, the following accommodations are required:

Classroom

- Alternate-format writing expectations (point form).
- This student may be using Computerized Note Taking software in your class. To do this effectively, the student will require copies of overhead/PowerPoint presentations/notes shortly before class. These items can be shared with the student electronically via Blackboard or e-mail.
- The student will be recording the class using a computer. It is understood that recordings are for this student's personal use only and will not be shared or distributed. The student has signed an "Intellectual Property Agreement" to that effect.

Assignments

- Extra time for assignments when negotiated in advance.
- Extensions on assignment deadlines when arranged in advance.
- Student may require flexibility with assignment submissions.
- Oral presentation one-on-one with you to evaluate his/her knowledge.
- Alternative format evaluations.

Test/Exam/Practicum:

- Use of the Test Centre to write Tests and Exams. The student will book in advance in the Test Centre. The student may decide not to use this accommodation for every assessment.
- Extra completion time when writing tests and exams; the student will book in advance in the Test Centre.:
- 1.5x
- Extra time to complete essays; the student will book in advance in the Test Centre.: 1.5x
- Tests and exams written alone in a separate room – see attached Test Centre Memorandum.
- Use of a computer with spelling, grammar, and style-checking capabilities for tests where writing is required; the student will book the Test Centre in advance.

In the case where faculty feels that any of the accommodations recommended above will undermine the academic integrity of their course, a discussion between Faculty and the Accessibility Consultant is recommended.

Please note that there may be minor adjustments to the recommended exam or classroom accommodations based on further educational assessments that may occur during the academic year.

Academic accommodations are meant to reduce or eliminate disadvantaging effects of students' disabilities for them to demonstrate their level of academic mastery of the course material. We have therefore asked that the student contact you to discuss this letter and discuss the accommodation plan.

Please respect the student's right to privacy by not publicly identifying the student in class.

Thank you for helping to make an accessible educational environment for all students.

ARTIFACT 2: STUDENT'S VIEW OF THIS LETTER OF ACCOMMODATION

MEMORANBUM

Health, Wellness and Accessibility Services

Letter of Accommodation

FROM: LOA provider

RE: Academic Accommodations for Alex

The above-named student is registered with the Health, Wellness and Accessibility Services office. Our office operates under the guidelines set forth by the Accommodation Policy and the Human Rights Code.

Presently this student has the following special circumstances:

- Uses an FM system. This is a wireless amplification system that involves the instructor wearing a small microphone. The instructions are transmitted directly to the student's ear through a specially-designed receiver.

Based on our review of the student's documentation, the following accommodations are required:

Classroom:

- Alternate-format writing expectations (biont form).
- This student may be using Computerized Note Taking software in your class. To bothis effectively, the student will require copies of overhead/downer point presentations/notes shortly before class. These items can be shared with the student electronically via Blackboard or e-mail.
- The student will be recording the class using a computer. It is understood that recordings are for this student's personal use only and will not be shared or distributed. The student has signed an "Intellectual Property Agreement" to that effect.

Assignments

- Extra time for assignments when negotiated in advance.
- Extensions on assignment deadlines when arranged in advance.
- Student may require flexibility with assignment submissions.
- Oral presentation one-on-one with you to evaluate his/her knowledge.
- Alternative format evaluations

Test/Exam/Practicum:

- Use of the Test Centre to write Tests and Exams. The student will do so in advance in the Test Centre. The student may decide not to use this accommodation for every assessment.
- Extra completion time when writing tests and exams; the student will do so in advance in the Test Centre:
 - 1.5x
- Extra time to complete essays; the student will do so in advance in the Test Centre.: 1.5x
- Tests and exams written alone in a separate room – see attached Test Centre Memorandum.
- Use of a computer with spelling, grammar and style-checking capabilities for tests where writing is required; the student will do so in the Test Centre in advance.

In the case where faculty feels that any of the accommodations recommended above will undermine the academic integrity of their course, a discussion between Faculty and the Accessibility Consultant is recommended.

Please note that there may be minor adjustments to the recommended exam or classroom accommodations based on further educational assessments that may occur during the academic year.

Academic accommodations are meant to reduce or eliminate disadvantageous effects of students' disabilities in order for them to demonstrate their level of academic mastery of the course material. We have therefore asked that the student contact you to discuss this letter and discuss the accommodation plan.

Please respect the student's right to privacy by not publicly identifying the student in class.

Thank you for helping to make an accessible educational environment for all students.

SCENARIO 3: ACCESSIBLE PARKING CHALLENGES ON CAMPUS

OVERVIEW: You are the administrative assistant working at the on-campus parking office that issues parking passes but does not deal with parking enforcement. A student, Leyla, has approached the counter seeking assistance. Leyla has low vision and uses a cane for mobility. She has difficulty walking long distances. In this scenario, as the user, you will need to respond to issues Leyla has regarding a parking ticket, access to make a complaint regarding services, access to make a complaint regarding a note left on her vehicle's windshield.

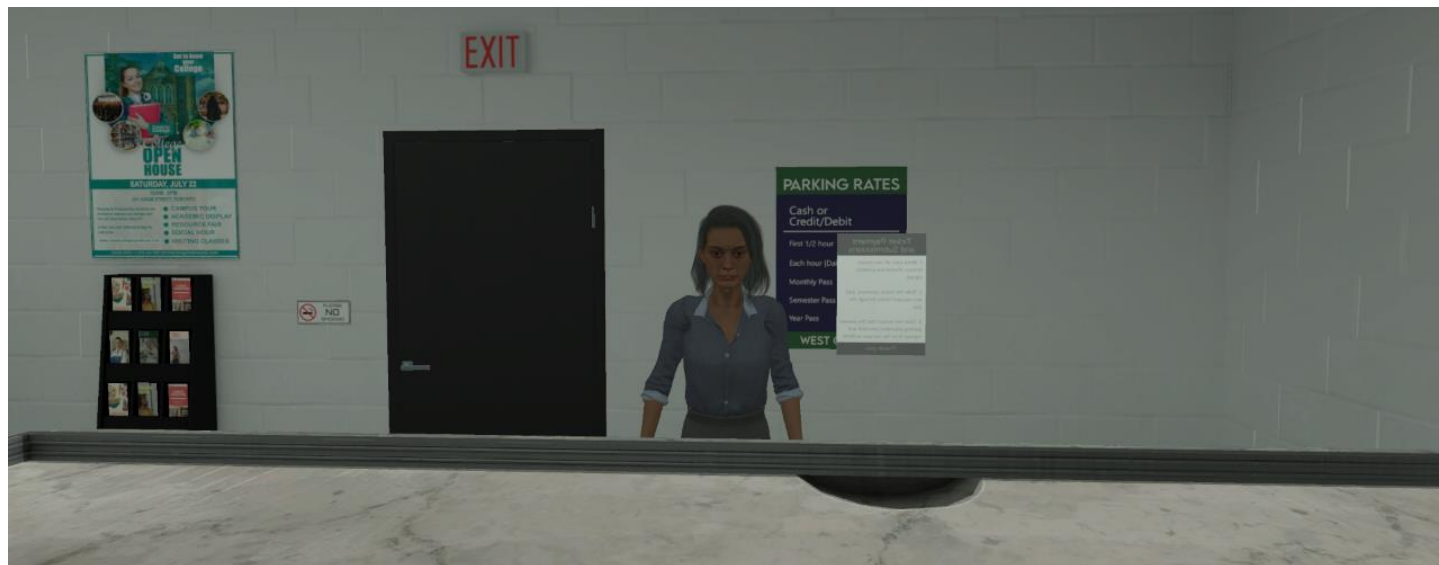

SCENARIO 3: INTERACTIONS

In scenario 3, the user will get the opportunity to select a few key elements in the scene that can be changed to better serve every member of the student and faculty body. The following objects in the simulation are interactable at certain points: Door; Campus Map; Glass Partition; Desk; Desk Speaker/Microphone; Sign on glass partition.

Enter the scenario and click "Begin" on the overview.

1. Complete the rest of the conversation with Leyla as you see fit.
2. Click "Continue" on the pop-up.
3. Go through the environment modification sequence and select the appropriate objects to update (in no order). Each object should highlight as you hover over it.
 - a. Door
 - b. Glass Partition
 - c. Desk
 - d. Desk Speaker/Microphone
 - e. Campus Map
 - f. Sign on glass partition
4. Click "Continue" on the pop-up.
5. Leyla appears for a debrief of the scenario after the scenario is complete.
6. Classroom debrief.

ARTIFACT SCENARIO 3

Here is the note that was left on Leyla's windshield while parked on campus.

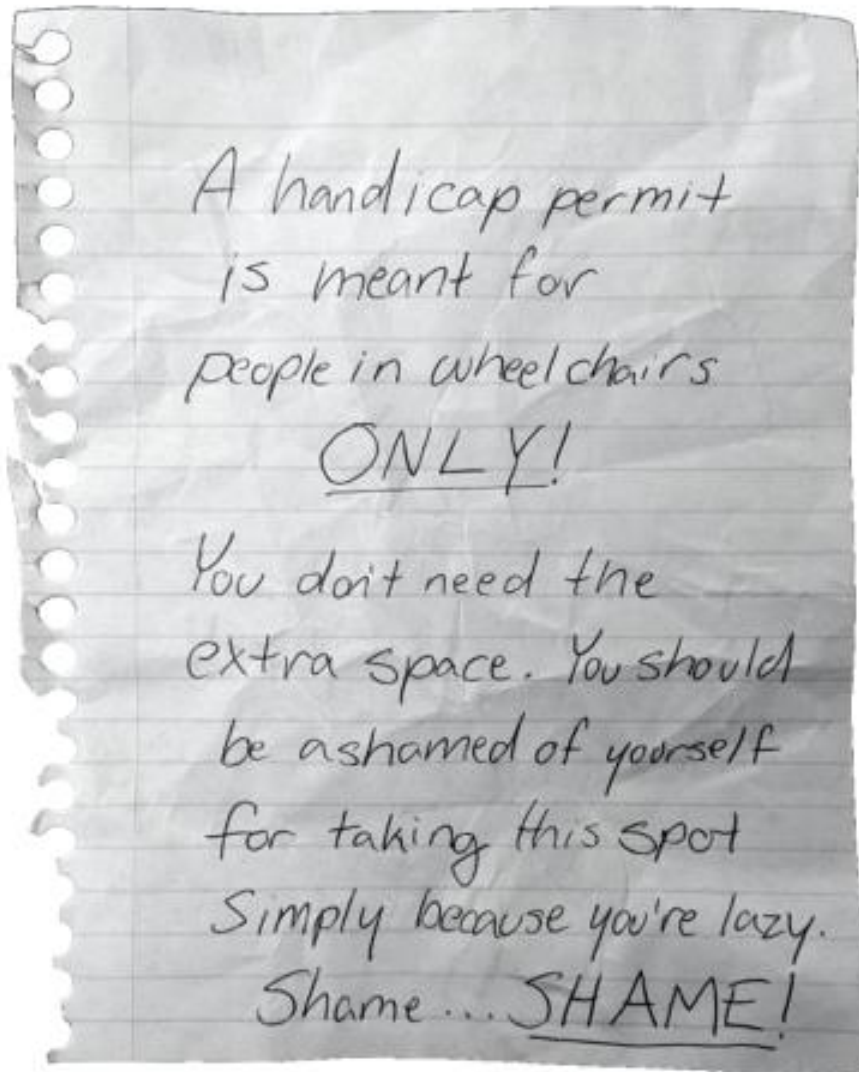

SCENARIO 4: ASSESSING ASSUMPTIONS AROUND WHEELCHAIR USAGE

Overview: You are a security guard working at the security office on campus. While on duty, Malik, a student who utilizes a wheelchair, comes in and is seeking assistance. Malik has received an email asking him to come to Campus Security to respond to a formal complaint made against him.

INTERACTIONS SCENARIO 4

In scenario 1, the user will get the opportunity to select a few key elements in the scene that can be changed to better serve every member of the student and faculty body. The following objects in the simulation are interactable at certain points: Malik's Wheelchair; Malik's Backpack; Privacy Walls, Doors, and Security Poster.



1. Enter the scenario and click "Begin" on the overview.
2. Complete the first interaction with Malik
3. Interact with Malik's wheelchair OR interact with the backpack on the ground
4. Complete the rest of the conversation with Malik as you see fit.
5. Malik appears for a debrief of the scenario after the conversation is complete.
6. Click "Continue" on the pop-up.
7. Navigate through the environment modification sequence and select the appropriate objects to update (in no order). Each object should highlight as you hover over it: **Door A; Door B; Security poster, Privacy Wall; and Chairs in front of desk.**
8. Click "Continue" on the pop-up.
9. Malik appears for a debrief of the scenario after the scenario is complete.
10. Classroom debrief.

ARTIFACT SCENARIO 4

Here is the security report based on a complaint made against Malik:

CELEBRATED COLLEGE/UTOPIAN UNIVERSITY SECURITY INCIDENT REPORT

Person Making Report: Sam Spade
Contact Information: sspade12@C-Uedu.ca
INCIDENT
Date: September 14 th
Time: 2:30 PM
Nature of complaint: Sexual harassment
Incident location: Campus Entrance (South)
Complaint against: I've never met the person, but I have a video (*Investigation results: Malik Markham)
Description of incident: I was going to class, and I saw this guy in a wheelchair. He was obviously being dropped off by his support worker. I didn't think anything of it until he pulled her towards him and started kissing her. I was so shocked that I took a video to prove it. I thought this should be reported, so I did. Here's the video: www.videoupload.com/334@430\$03432

WHEN YOU ARE FINISHED... PACKING UP

When finished with the headset, please ensure the following are packed into each case:

- VR Headset
- 2 Controllers

On the Lid of the case:

- 2x USB-C cables
- USB-C Charger



For additional resources visit: <https://sites.google.com/view/user-guide-for-vr-simulations/resources-on-accessibility>



User Guide for Simulations

Glossary of Terms

Disablism

has been defined as “discriminatory, oppressive or abusive behavior arising from the belief that disabled people are inferior to others” (Miller et. al., 2004, p. 9). Disablism thus includes widespread belief systems that devalue disabled lives, as well as a range of resulting practices including schoolyard bullying, the use of disability-related terms as insults, and institutionalization (Campbell, 2009; Withers, 2012). Disablism also, however, underlies less obvious forms of “social oppression involving the social imposition of restrictions of activity on people with impairments and the socially engendered undermining of their psycho-emotional wellbeing” (Thomas, 2006, p. 73). Thus, disablism is also evident in daily struggles to make friends, exclusions from recreational activities, hurtful ‘jokes’, and structural barriers within higher education. In sum, disablism involves beliefs, processes, and practices that (intentionally or not) serve to harm, exclude, and restrict opportunities for disabled people based on the *negative ontology of disability*: the assumption that disability is an all-encompassing and entirely negative identity, which makes one inferior to non-disabled people (Campbell, 2009). *Disablism* is simply the explicitly discriminatory manifestation of a much more widespread, and far less openly problematized, phenomenon called *ableism*.

Ableism

A network of beliefs, processes and practices that produce a particular kind of self and body (the corporeal standard) that is projected as the perfect, species-typical, and therefore essential and fully human. Disability then is cast as a diminished state of being human. (Campbell, 2008, p. 44)

In other words, the discriminatory mistreatment of disabled people (disablism), is a direct result of the devaluation of people who cannot live up to ideals of non-disabled normativity.

It is much harder to identify and extricate ourselves—and our fields—from ableist assumptions and actions, even if we are motivated to do so. This is because ableist assumptions form the often-unexamined foundations of much disciplinary knowledge, practice, and values the fields have inherited. This conundrum is at the heart of Lyons' (2013) conceptualization of **enlightened ableism**.

In their study of inclusive education, Lyons (2013) highlighted how teachers often explicitly supported disability inclusion, and could clearly articulate its benefits, yet they did not seem able to identify and redress longstanding practices of segregation and exclusion. The author concluded that it is unlikely that inclusion legislation or policy transforms classroom practices. Rather, such top-down changes likely create an enlightened rhetoric that serves to mask the continuation of ableist (and potentially disablist) practices, thus failing to decrease the inclusive education gap. In Lyons' (2013) words: "the rhetoric of enlightened ableism presents a rational, modern, well-informed view of the world, yet allows the continuation of practices that marginalize people with disabilities" (p. 240). In other words, people can be doing entirely well-meaning work around inclusion and empowerment, and still help to reproduce a world in which disabled people are devalued and excluded because they do not live up to the supremacist, ableist expectations of bodies, minds, and capacities.

NOTE: the above material has been excerpted from Peers, D., Eales, L., and Goodwin, D. (2023) Disablism, Ableism, and Enlightened Ableism in Contemporary Adapted Physical Activity Textbooks: Practising What we Preach? In D. Goodwin and M. Connolly (Eds) (2023) Reflexivity and Change in Adaptive Physical Activity, pp. 34-46. Routledge.

Accessibility

Is defined as the degree to which a product, device, service, or environment is available to as many people as possible. Accessibility can mean different things to different people based on their experiences of the body, their stage of life, their physical environment, and so on. Creating a society where all members can participate fully in their community is one of the goals of accessibility.

Source: Anzovino, T., & Oresar, J. (2019). *Walk a Mile: A Journey Towards Justice and Equity in Canadian Society*. Toronto: Nelson Publishing.

For a glossary of technical terms please visit:

<https://sites.google.com/view/user-guide-for-vr-simulations/glossary-of-terms>

Project Partners

Niagara College Canada, Brock University and XpertVR.



Project Funders

Funded by the Government of Ontario and eCampus Ontario.



This project is made possible with funding by the Government of Ontario and through eCampusOntario's support of the Virtual Learning Strategy. To learn more about the Virtual Learning Strategy visit: <https://vls.ecampusontario.ca>.